

PowerPulse

Thank you for choosing
EcoFlow residential EV charger!



Contents

Product Details

System Overview

Power Supply from Grid

Power Supply from Solar
Energy and Grid

Power Supply Distributed
by EcoFlow PowerOcean

Installation Preparation

App Functions

Connect to EcoFlow App

Load Balancing

Plug and Play

Scheduled Charging

Electricity Bill Settings

Share Device

View Data

Charging Mode ¹

Extended Functions

Add Homepage Widget

Set the Minimum Charging
Amount

Specifications

Safety Instructions >



Installation and
Wiring



Set Up Smart
Meter



Look Up Error
Code



Download
EcoFlow App

Product Details

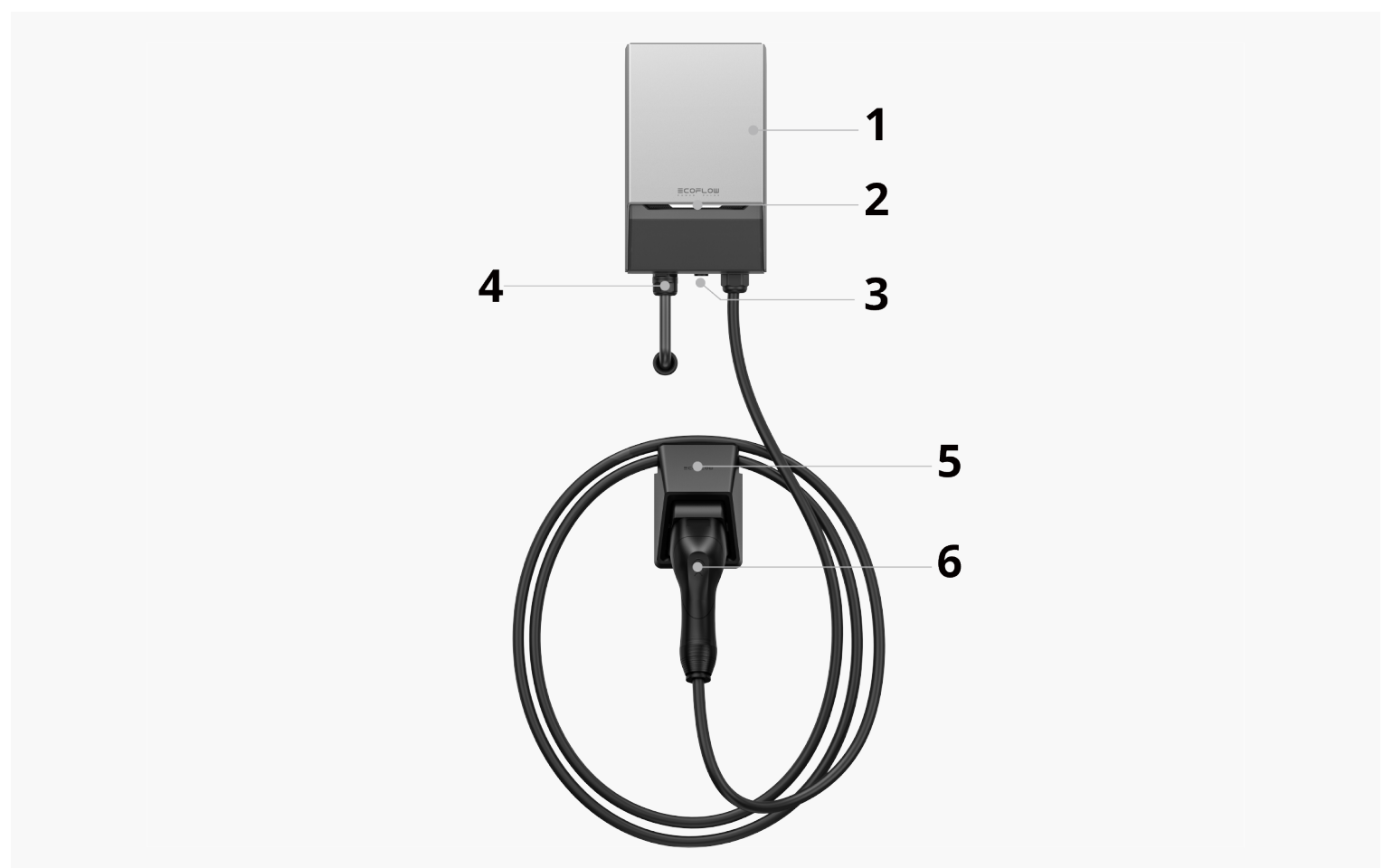

1 Main charging box

Installed in both indoor and outdoor environments.

2 Indicator light

The white light indicates the charging status; and the orange light indicates a fault alarm. Please check the solution in the app.

3	Communication port	Can communicate with smart meters or PowerOcean systems through RS485 wired connection.
4	Power input port	Supports access to single-phase or three-phase home circuit systems.
5	Cable holder dock	Can be installed in both indoor and outdoor environments. It is recommended to install it below or on the left side of the main charging box.
6	Charging cable	Please ensure that socket types of the vehicle and EV charger are compatible (Type 2, IEC 62196-2).

System Overview

This product is compatible with **single-phase/three-phase home power systems** and can provide **1.38-11kW charging output**. The product can be used independently, but is recommended to use with a smart meter (ADL400) to maintain load balance. It can also be connected to a solar inverter system and a home solar battery system for more cost-effective and environmentally friendly electricity use scenarios.

In different electricity use scenarios, this product only needs to make a physical electrical connection with the household main distribution box (or smart distribution box), and it can adjust the power source and current size through communication with external devices. Please see the following chapters for specific communication methods.

Power Supply from Grid

In the current scenario, follow the instructions in this manual to complete the product installation and electrical wiring steps. It will work normally after powering on for self-test. When using it, you can customize the charging current in the EcoFlow app, or select the fast charging mode (16A).

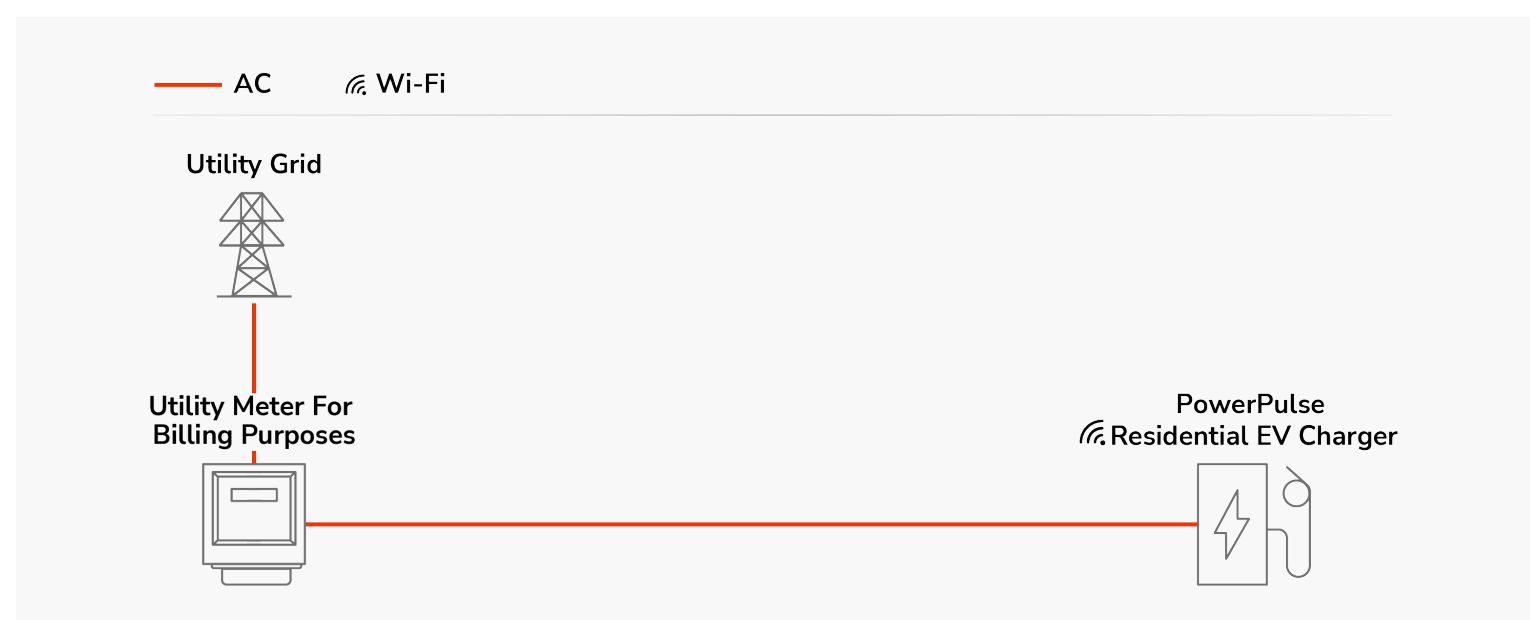

Load Balancing

If there are too many load devices on household branch circuits for a long time, or if there are peak electricity usage regulations in the local power grid, power restrictions may be triggered, causing charging interruption or even tripping. In order to avoid such incidents, it is recommended to install a smart meter (ADL400) to communicate with this product and activate the **dynamic load balancing function** ¹.



After the load balancing function is turned on, please set the maximum load current of the household according to the main circuit breaker parameters. The product will read the real-time load current of the smart meter and always intelligently charge the car with the maximum current allowed by the system ($\leq 16A$). While maintaining fast charging, it also maintains the stability of circuit operation.

	Without meter	With meter
Power Source	Grid	Grid
Power System	Single-phase/Three-phase	Single-phase/Three-phase
Phase Switching	Not supported	Not supported
Load Balancing	Not supported	Supported (needs to be turned on manually)
Communication Method	/	RS485 wired connection
Communication Object	/	Smart meter (ADL400)
Charging Current	Custom	Intelligent adjustment
Charging Mode	Manual mode and fast charging mode	Manual mode and fast charging mode

i Maximum current supported by load balancing ¹

In practical use, the current in custom mode or fast charging mode may exceed the maximum allowed by the home power system. In this case, the smart meter will reduce the current of the EV charger circuit to maintain system stability.

Power Supply from Solar Energy and Grid

In the current scenario, it is necessary to complete the product installation, electrical and meter communication wiring steps, and ensure that the home solar inverter system is connected to the grid, so that PowerPulse can work normally after powering on for self-test.

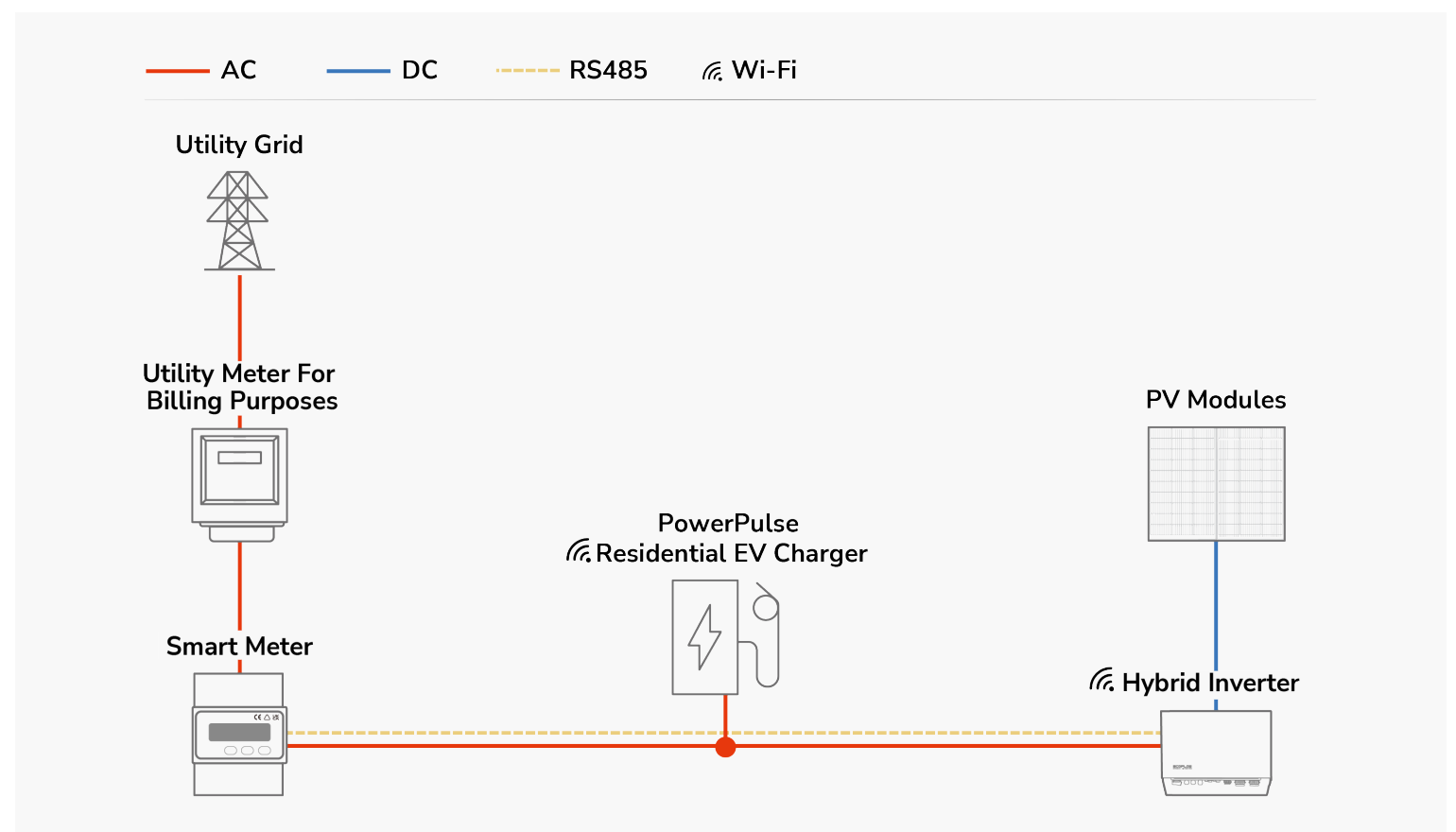

When using it, you can choose custom, fast charging or solar charging mode in the EcoFlow app. After selecting the solar charging mode, the EV charger will draw power from solar energy first. When the real-time solar energy input is not enough to maintain the minimum power of the EV charger (single-phase 1.38kW and three-phase 4.2kW), the EV charger will draw power from the grid to ensure that the charging current remains $\geq 6A$ to maintain the normal operation of the EV charger.

Power Source	Grid and solar energy
Power System	Single-phase/Three-phase
Phase Switching	Not supported
Load Balancing	Supported (needs to be turned on manually)
Communication Method	RS485 wired connection
Communication Object	Smart meter (ADL400)
Charging Current	Intelligent adjustment
Charging Mode	Manual mode, fast charging mode, and solar charging mode

Power Supply Distributed by EcoFlow PowerOcean

In the current scenario, it is necessary to complete the product installation, electrical and communication (with PowerOcean system) wiring steps, and ensure that the home solar battery system is connected to the grid, so that PowerPulse can work normally after powering on for self-test.

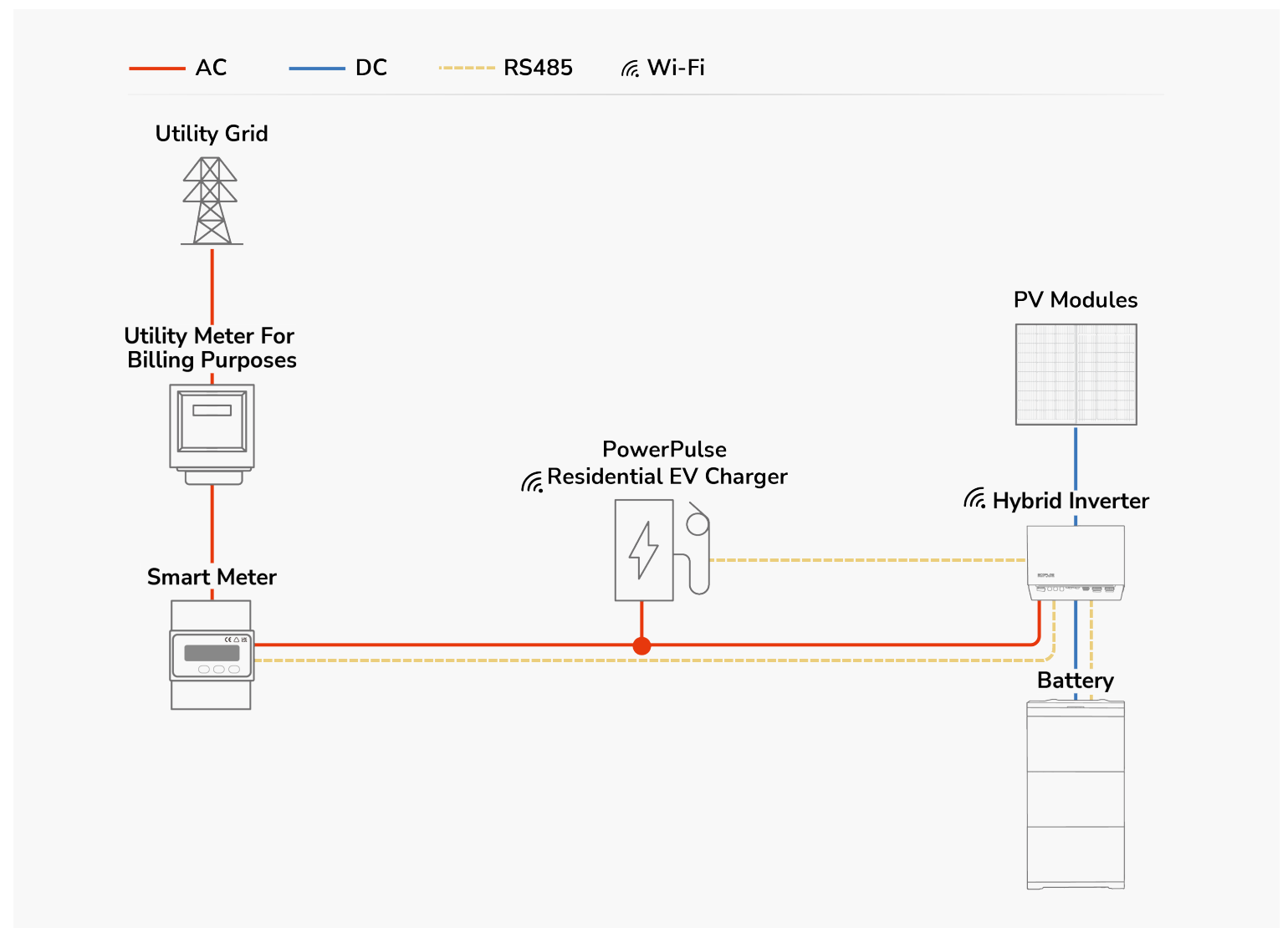

Power Source	Grid, solar energy, and battery pack (grid-connected)
Power System	Single-phase/Three-phase
Phase Switching	Supported
Communication Method	RS485 wired connection and Wi-Fi connection
Communication Object	Home solar battery system (PowerOcean)
Charging Current	Intelligent adjustment
Charging Mode	Intelligent adjustment (see description below for details)

When using the product, you can enter the PowerOcean device homepage from the EcoFlow app and select PowerPulse in the **homepage widget** ¹ to control the start and stop of charging or view historical charging data.



Homepage widget ¹

Please check the steps in "Extended Functions - Add Homepage Widget".

Smart Charging

You can set the *minimum charging amount* according to your daily travel needs, and EcoFlow PowerOcean will always allocate the **maximum power** ¹ to the EV charger for

charging. After reaching the minimum battery level, it will **continue to charge the vehicle** ² until the battery is fully charged.

 **Maximum power** ¹

Hybrid charging from grid, solar energy, and battery packs. PowerOcean will self-generate power for self-consumption when charging. Please refer to the PowerOcean user manual for detailed explanation.

Charging logic ²

After the minimum charging amount is reached, PowerOcean will prioritize solar energy input for charging power supply. When the solar energy input is lower than the minimum charging power, PowerOcean will draw power from the battery pack and the grid to ensure uninterrupted charging.

Dynamic Phase Switching Function

The PowerOcean system supports **intelligent phase switching** ¹ in single-phase and three-phase power systems.

In the charging process of a normal three-phase solar energy system, when the generated solar power is lower than the minimum discharging power of the load device, the charging process will often be stopped, or will be completely switched to drawing power from the grid. In addition, due to power grid regulations in some countries or regions, there are clear limits on the power load during peak power consumption. A single power consumption strategy may cause the EV charger to malfunction.

When this product communicates with the PowerOcean system, if the remaining discharging capacity of the solar energy and battery pack is lower than the minimum charging power of PowerPulse (three-phase, 4.14kW), the system will automatically switch to single-phase charging mode, supporting a minimum power of 1.38kW for charging the car.

When the remaining discharging capacity of the solar energy and battery pack is lower than 1.38kW, PowerOcean will draw power from the grid to maintain normal operation.

 **Intelligent phase switching** ¹

Only phase switching in three-phase systems is supported.

Pairing

When this product communicates with PowerOcean, you can choose wired connection or Wi-Fi pairing (**recommended order: wired connection + Wi-Fi > wired connection > Wi-Fi**). After completing the basic steps, please follow the PowerOcean communication tutorial video for the next step of pairing.

Installation Preparation

Before installing the product, make sure to confirm the following basic conditions, and thoroughly read and understand the contents of the "[Installation Guide](#)" to ensure electrical safety and convenient use.



Home Circuit Check

- Check the type of home electrical system (single-phase/three-phase);
- Calculate the total home electrical load and determine if it can support the maximum power operation of this product.



Installation Check

- Confirm wiring methods to ensure compliance with fire, electrical, and building regulations.



Installation Accessories/Tool List

- Prepare the necessary accessories and tools according to the power usage scenario, and ensure that they meet the requirements of this product;
- Make sure that wires and circuit breakers are safe and undamaged.



Maintenance and Inspection Requirements

- The electrical wiring steps must be performed by a qualified electrician;
- Keep the EV charger socket clean and dry. If it gets dirty, please wipe it with a clean, dry cloth;
- Do not attempt to disassemble, repair or refit the EV charger. If necessary, please contact the qualified technician. Improper operation will result in device damage, electric leakage and other hazards.

App Functions

Connect to EcoFlow App

[Download EcoFlow App](#)

When using the product, please first add the device via Bluetooth on the EcoFlow app and configure it under your home Wi-Fi to remotely control the product or view data.

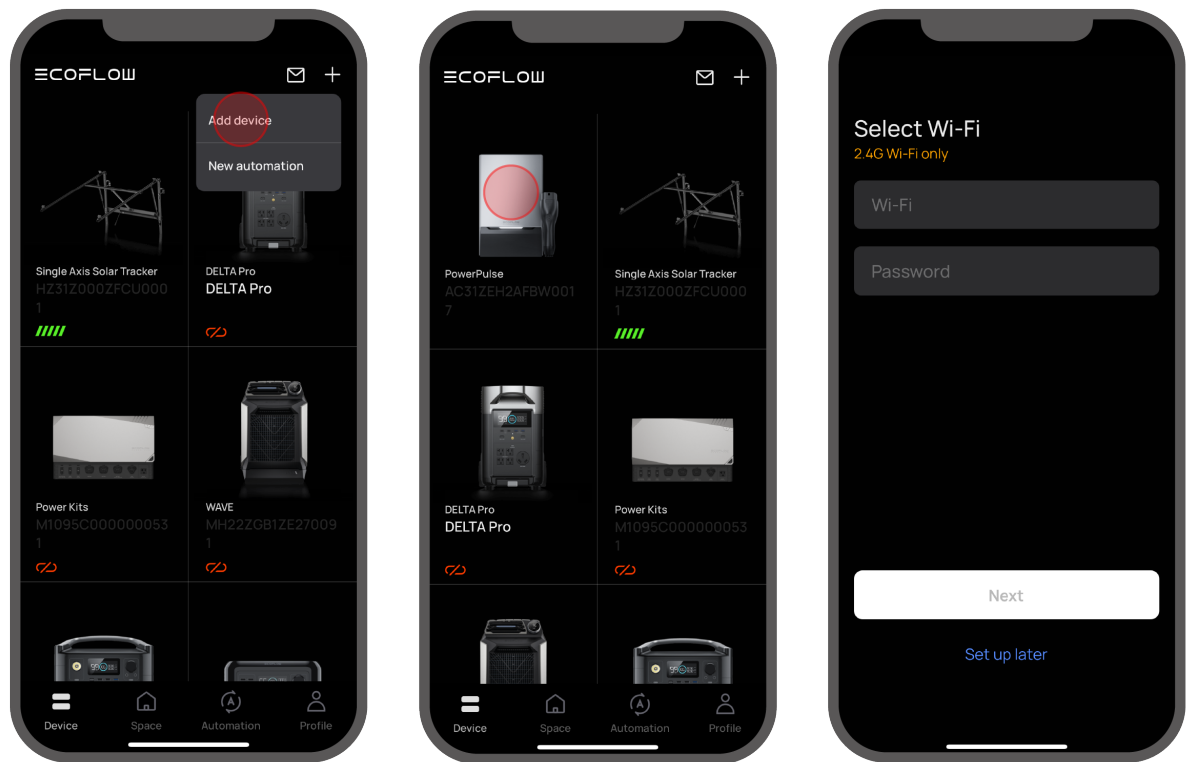

Once pairing is complete, you can start charging your car. When charging, follow the steps below.

Start charging: Insert the charging cable into the car charging port, and then tap [Start Charging] on the device homepage of the app.

Stop charging: Tap [Stop Charging] on the device homepage of the app, and then pull out the charging cable.

Notice

- To ensure system stability, functions such as charging mode setting, load balancing, firmware upgrade, and data clearing are not supported during the charging process. Please operate after the charging is stopped;
- Due to the high charging power, this product does not allow hot swapping. Please wait until the [Stop] icon is completely loaded on the app before pulling out the charging cable.

Load Balancing

After PowerPulse communicates with the smart meter (ADL400), you can turn on the load balancing function.

- **Settings: Device settings - Load balancing - Set the maximum current of the metered circuit - Save**

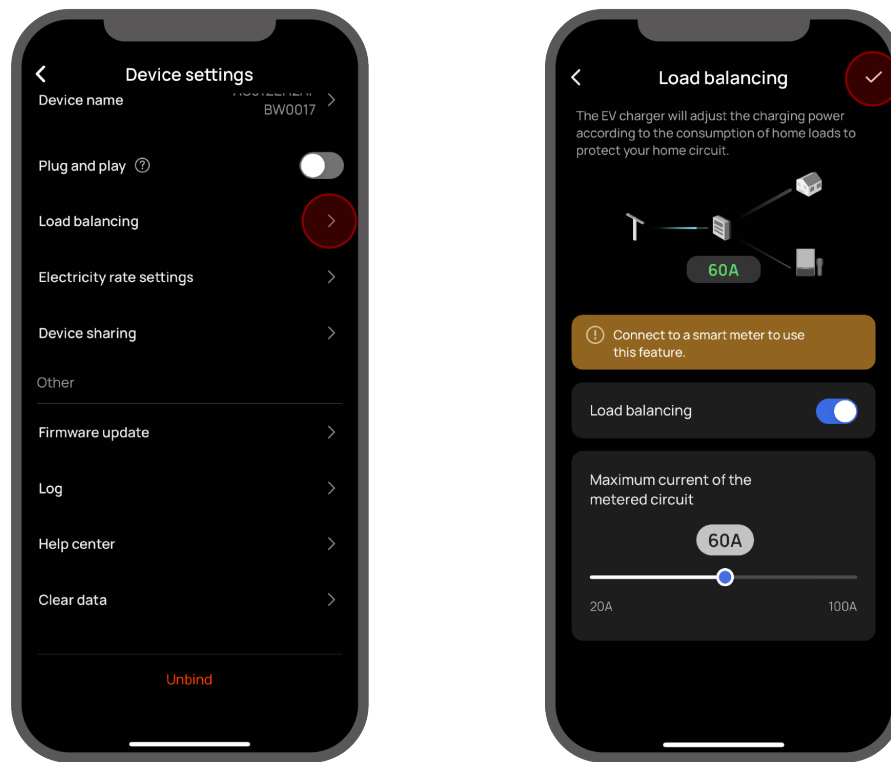

Plug and Play

After adding this product to the EcoFlow app, the plug-and-play function can be turned on. After turning it on, plug the charging cable directly into the car charging port to start charging.

- **Settings: Device settings - Plug and play**

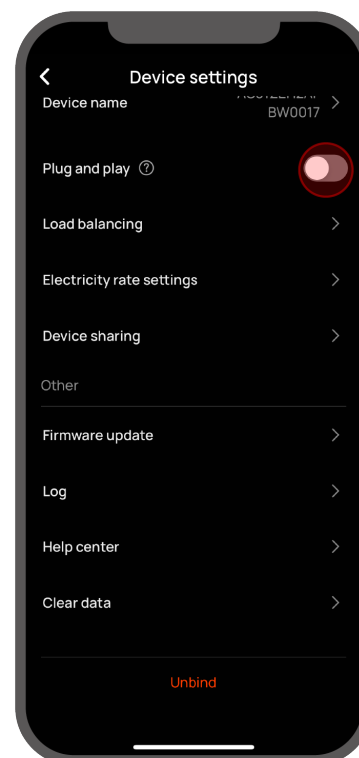

Notice

- Please ensure that the device is securely protected to prevent unauthorized use by third parties;
- Before stopping charging, you still need to tap or slide [Stop Charging] on the app, and then pull out the charging cable.

Scheduled Charging

This product can be scheduled for charging according to your daily needs. When

setting the schedule, you can set the charging start time and charging mode, and PowerPulse will charge according to the set requirements.

- **Settings: Device homepage - Schedule - Add - Create**

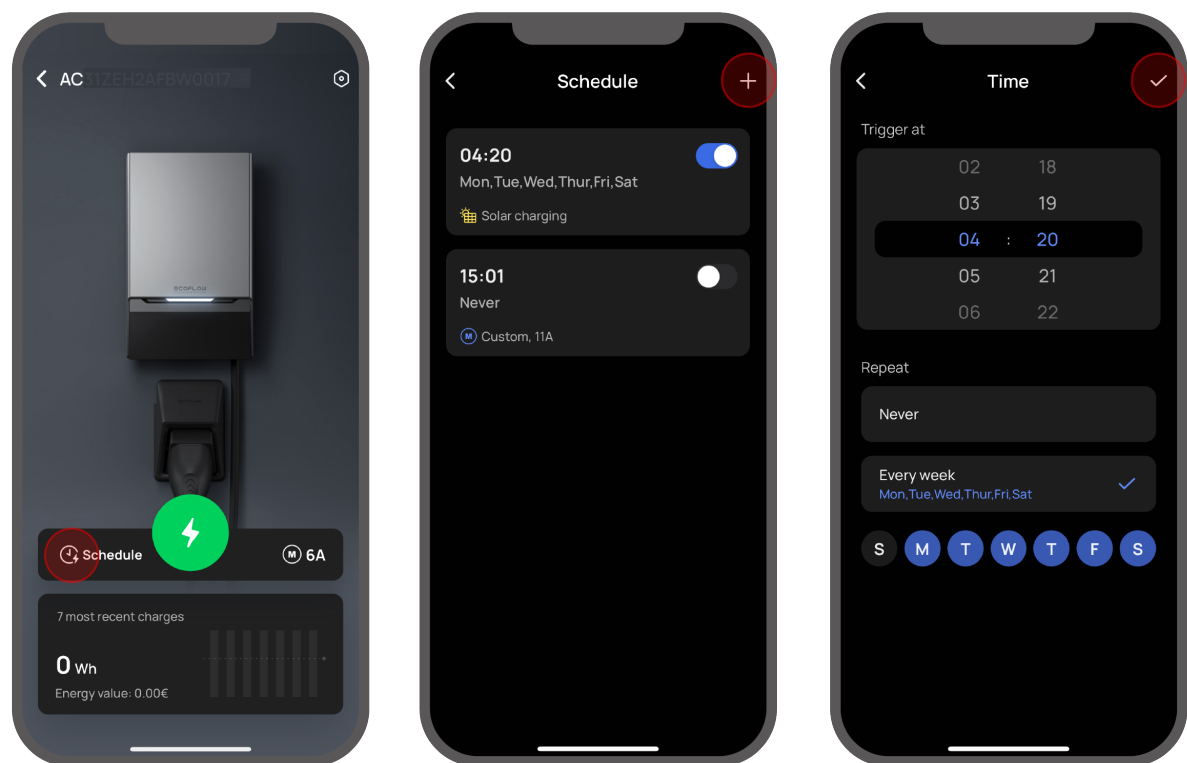

Electricity Bill Settings

You can set electricity prices, consumption peaks and peak hours according to local standards. After setting up, you can view the estimated electricity cost in the Electricity rate - Charging details - Dashboard.

- **Settings: Device settings - Electricity rate settings**

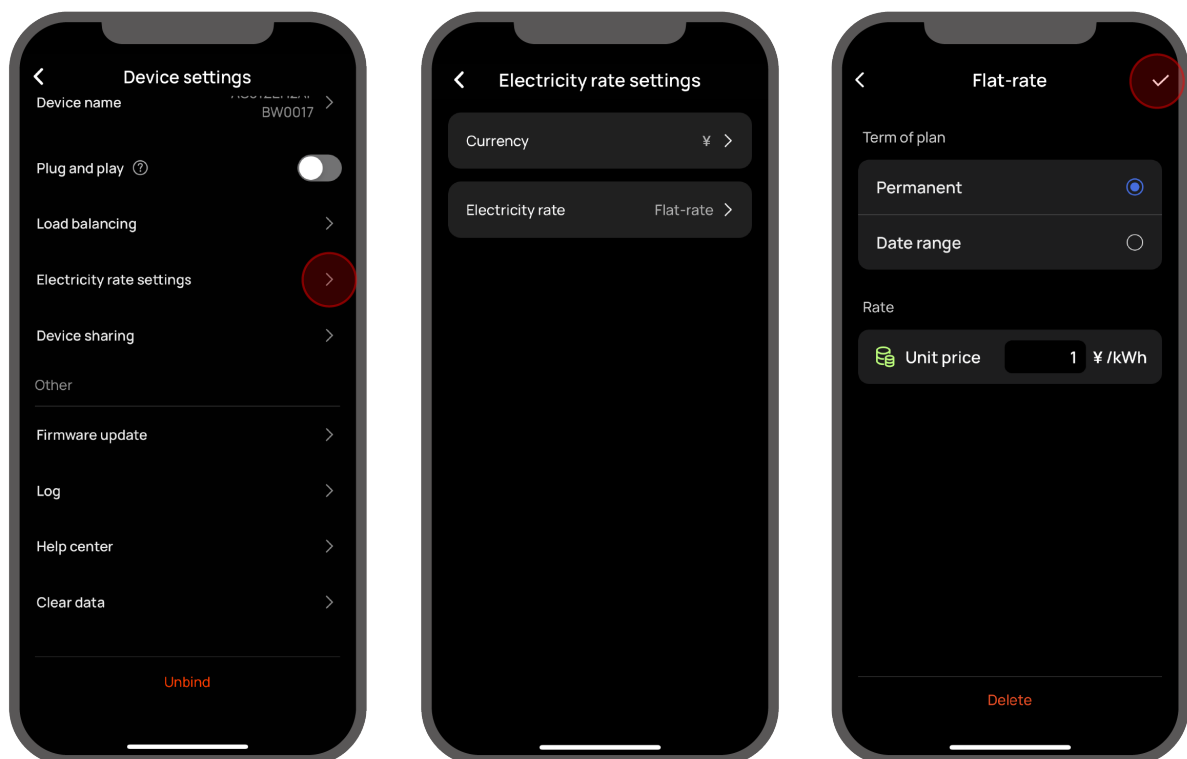

Share Device

This product only supports binding to one main account. You can share it with other EcoFlow app accounts (no more than 10) so that other users can use the EV charger directly through the app.

If you need to cancel the sharing, swipe left on the shared account icon to delete it.

- Settings: Device settings - Device sharing

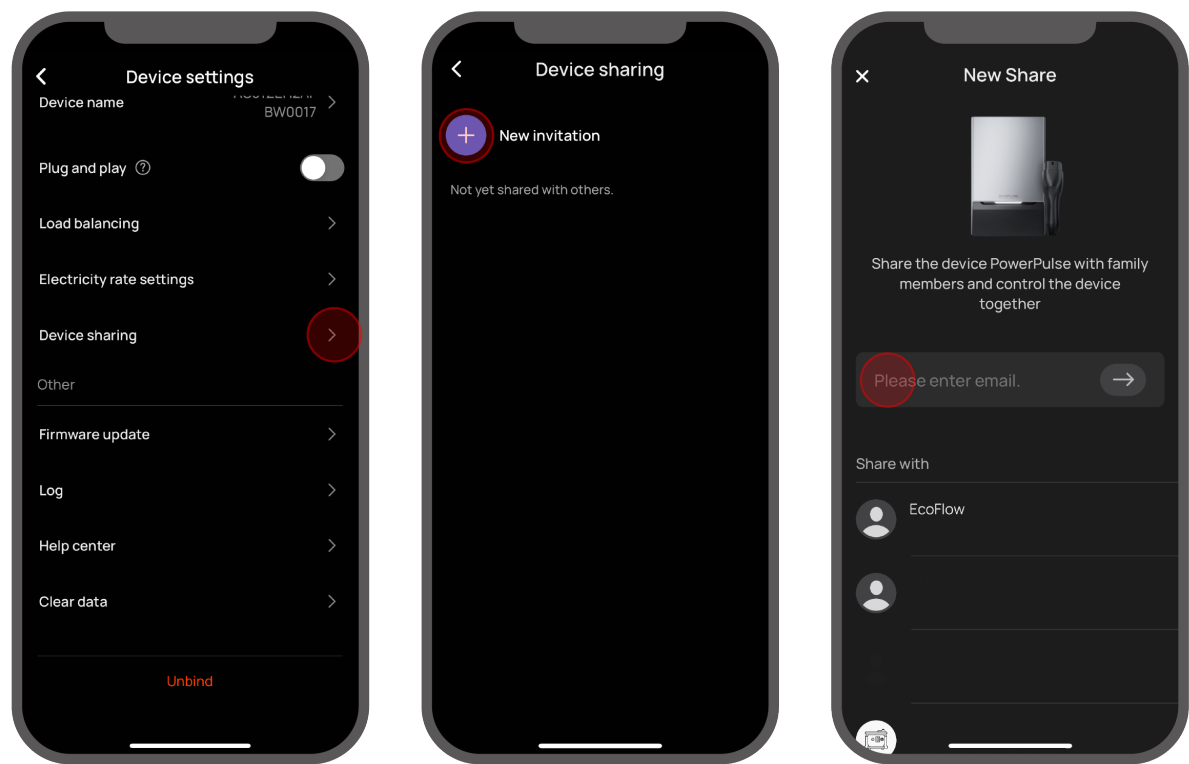

View Data

You can view ongoing charging data, daily, weekly, monthly, and annual charging reports, as well as charging logs. You can also clear all charging data in the app. Please see below for specific steps.

View charging data in progress:

- Device homepage - Charging details

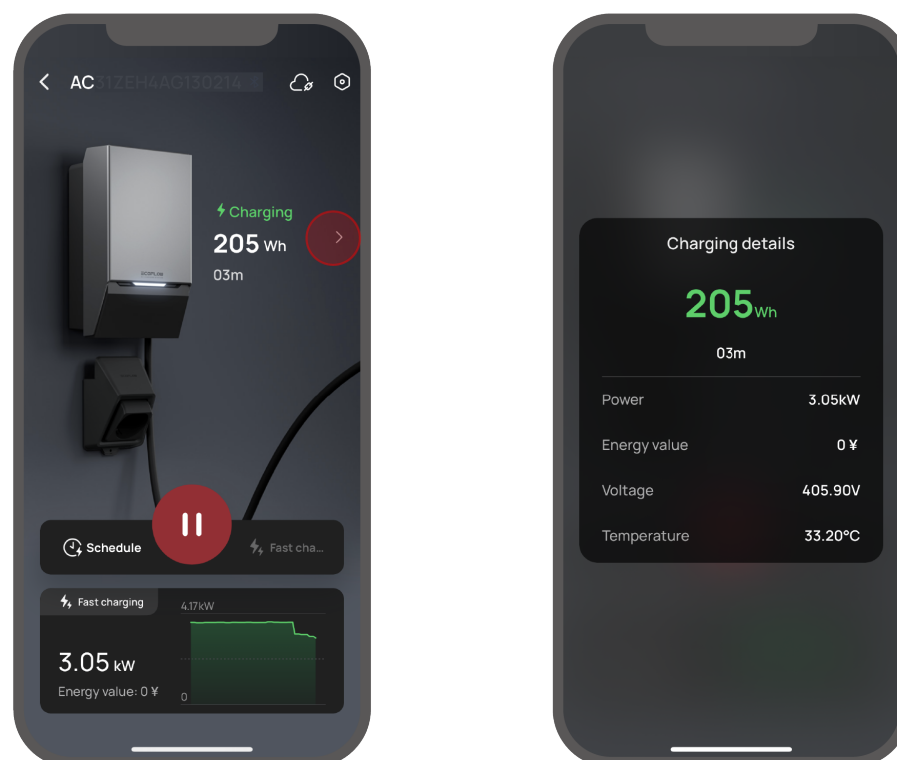

View daily, weekly, monthly, and annual charging reports:

- Device homepage - Dashboard

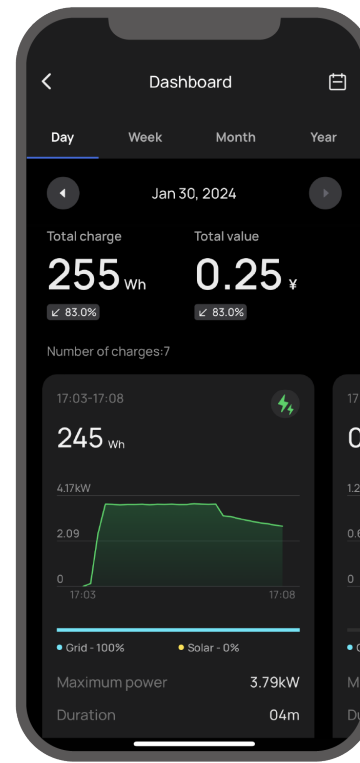
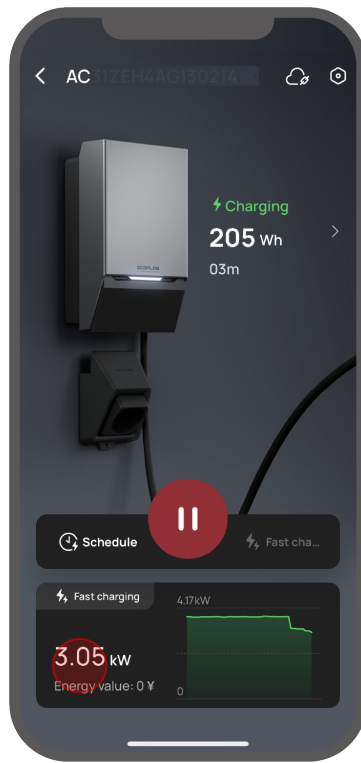

Charging logs:

- Device settings - Log

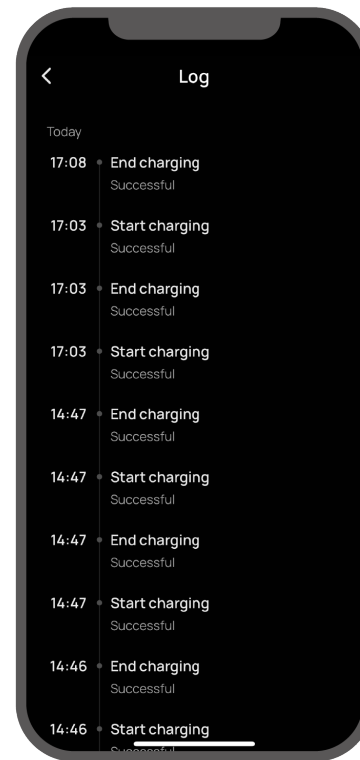
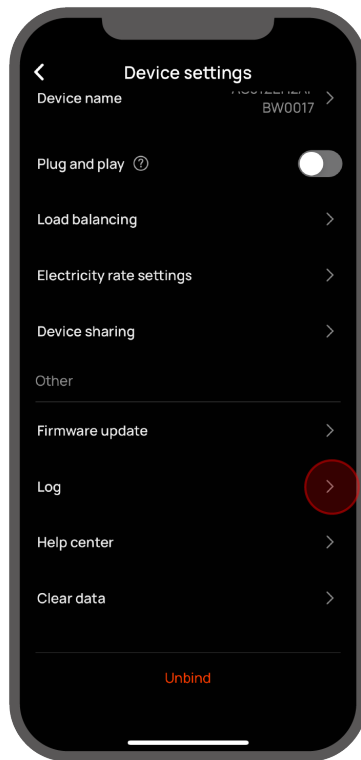

Clear data:

- Device settings - Clear data

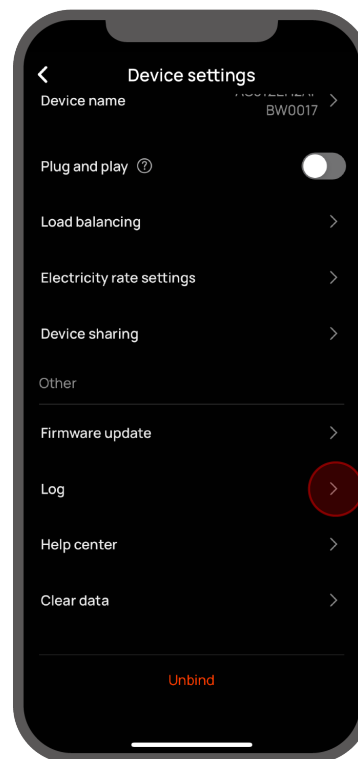

Charging Mode ¹

You can customize the **charging current** ² in the PowerPulse device homepage of the EcoFlow app, or select fast charging mode (continuous charging at the maximum current of 16A).

If your home solar inverter system is connected to the grid, you can experience the solar charging mode. After selecting the solar charging mode, the EV charger will draw power from solar energy first. When the real-time solar energy input is not enough to maintain the minimum power of the EV charger (single-phase 1.38kW and three-phase 4.2kW), the EV charger will draw power from the grid to ensure that the charging current remains $\geq 6A$ to maintain the normal operation of the EV charger.

Charging mode ¹

It can only be set on the PowerPulse device homepage on the app. After PowerPulse communicates with the PowerOcean system, please perform smart charging directly on the PowerOcean device homepage.

Charging current ²

The custom current only represents the maximum charging current, and the actual charging power is subject to the demand of the car.

Extended Functions

After PowerPulse communicates with PowerOcean, you can experience the following functions on PowerOcean's device homepage.

Add Homepage Widget

After connecting the device, you can add the PowerPulse widget to the PowerOcean device homepage to quickly and easily control the start and stop of charging, view charging data, etc.

Settings:

1. PowerOcean device homepage →
2. Edit (at the bottom of the page) →
3. Widget →
4. Add PowerPulse (long press the widget and drag to place it) →
5. Save

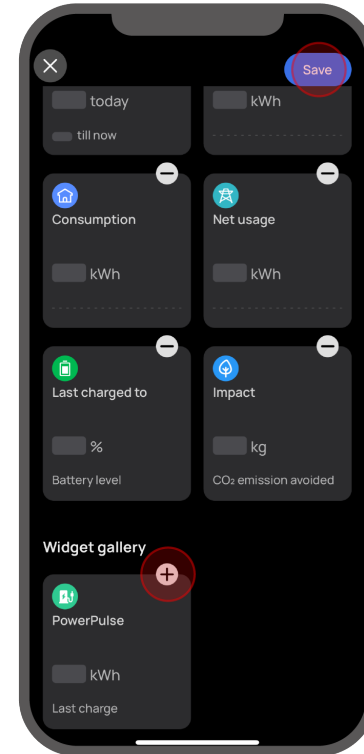
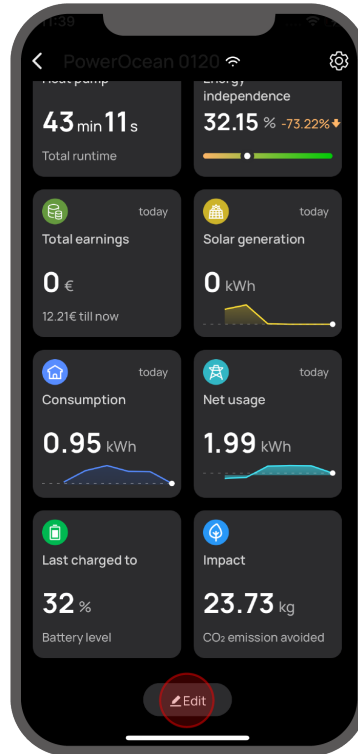

Set the Minimum Charging Amount

You can set the *minimum charging amount* according to your daily travel needs, and EcoFlow PowerOcean will always allocate the **maximum power**¹ to the EV charger for charging. After reaching the minimum battery level, it will **continue to charge the vehicle**² until the battery is fully charged.

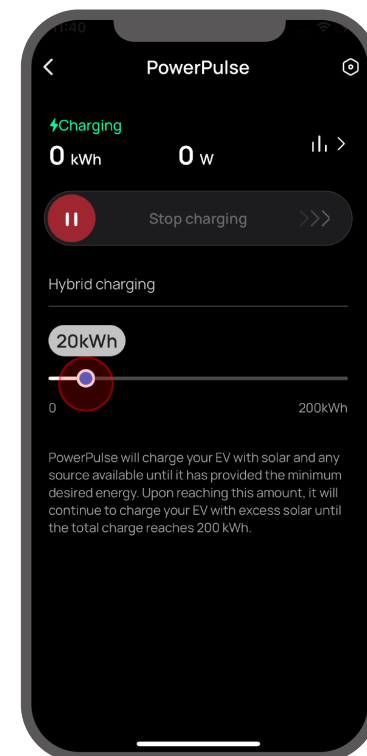
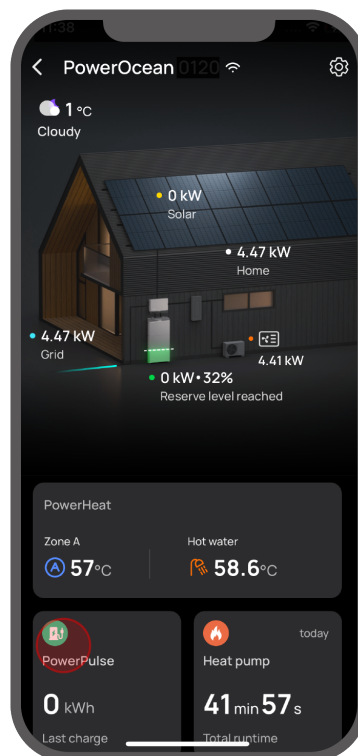

i **Maximum power** ¹

Hybrid charging from grid, solar energy, and battery packs. PowerOcean will self-generate power for self-consumption when charging. Please refer to the PowerOcean user manual for detailed explanation.

Charging logic ²

After the minimum charging amount is reached, PowerOcean will prioritize solar energy input for charging power supply. When the solar energy input is lower than the minimum charging power, PowerOcean will draw power from the battery pack and the grid to ensure uninterrupted charging.

Specifications

- Model: EF-PP-H01-1

Input & Output specifications

AC input (three-phase)	400V~ 16A per phase (L1/L2/L3/N/PE)
AC output (three-phase)	400V~ 16A per phase, max. 11kW, mode 3
Rated frequency	50 Hz
Approved grid configurations	TN, TT
RCD	TypeA+6mA DC detection

Communication

Wi-Fi (2.4G)	Frequency range: 2400~ 2484.5 MHz Maximum output power: 20 dBm
Bluetooth	Frequency range: 2412~ 2480 MHz Maximum output power: 10 dBm

Environment requirement

Ambient temperature for storage	- 40°C to +70°C
Ambient temperature for operation	- 30°C to +50°C
Relative humidity	5% to 95%

Basic information

Net weight	Approximately 3.3 kg
Dimensions	Charging box: 283x178x99 mm Charging cable: 5 m
Altitude	≤ 2000 m
Pollution Degree	3
IP rating	IP65

Safety Instructions

Disclaimer

Before using this product, please read and fully understand this document and all related documents of this product. After reading this document, please keep it well for future reference. Failure to properly operate this product could cause serious injury to yourself or others, or damage to this product and other property. By using this product, you are deemed to have understood, acknowledged and accepted all terms and contents of this document. The user undertakes to be responsible for his/her actions and all consequences arising therefrom. EcoFlow is not liable for all losses caused by the user's failure to use this product according to the disclaimer and safety instructions.

EcoFlow reserves the right of final interpretation of this document and all related documents of this product where permitted by laws and regulations. These documents are subject to update, revision or termination from time to time without prior notice, please visit EcoFlow website for the latest product information.

Installation

1. The installation and operating environment must meet relevant international, national, and local standards, and are in accordance with the local laws and regulations.
2. Ensure the product is protected against lightning and heavy rain.
3. Keep the product away from explosive or flammable materials, chemicals, vapors and other hazardous objects.
4. The mounting structure where the equipment is installed must be fire resistant. Do not install the equipment on flammable building materials.
5. Ensure that the installation surface is solid enough to bear the weight of the equipment.
6. Reserve sufficient clearance around equipment to ensure sufficient space for installation and heat dissipation.
7. Adaptors or conversion adaptors are not allowed to be used. Cord extension sets are not allowed to be used.

Wiring

CATUTION:

1. The electrical wiring steps must be performed by a qualified electrician.
2. Before connecting to the power source, make sure that the main circuit is disconnected. Wear insulated protective equipment when operating, otherwise serious personal injury can occur.
3. Certified RCBO should be installed upstream close to the charging station, All these protection devices shall be chosen with appropriated technical

specification, working voltage \geq charging station working voltage, working current \geq charging station working current, Ingress Protection (IP) \geq IP54 or installed inside IP54 protection box for outdoor use.

4. For safety reasons, it is recommended that you add a surge protection device (before RCBO) to your home distribution box.

Use and Disposal

1. Do not touch the socket pin when the product is powered on.
2. Do not use the EV charger if it shows any visible product damage such as cracks, abrasions, bare leakage, and other visible defects. Contact a qualified technician immediately at the first sign of such damages.
3. Do not attempt to disassemble, repair or refit the EV charger. If necessary, please contact the qualified technician. Improper operation will result in device damage, electric leakage and other hazards.
4. In case any abnormal condition happens, please turn off incoming power supplies immediately.
5. During charging, do not drive the EV. Charge only when the EV is stationary. For hybrid cars, charge only when the engine is switched off.
6. Keep children away from the EV charger.
7. Keep the EV charger socket clean and dry. If it gets dirty, please wipe it with a clean, dry cloth.
8. Our packaging materials are environmentally friendly and can be recycled. Please put the packaging in applicable containers to recycle it. Do not dispose of this device with household waste. It should be taken to a suitable facility for recycling electrical and electronic devices. For more detailed information about recycling of this product, please contact your local city/town council office or your household waste disposal service.