

# Installation & User Manual

# Table of contents

Safety Information.....	3
1. General Information .....	4
2. Technical Features .....	5
2.1 Technical Details .....	6
2.2 Technical Drawings .....	8
2.3 Connections .....	12
3. Installation .....	177
3.1 Location.....	17
3.2 Hydraulic Connections .....	17
3.3 Three- Way Thermostatic Mixing Valves .....	18
3.4 Connection Recommendations.....	19
3.5 Installation Examples .....	19
3.6 Installing the DHW Tank.....	20
4. Maintenance .....	21
5. Security .....	22
5.1 Electrical Kit.....	22
5.2 Electrical Schematics.....	22
5.3 Electrical Elements.....	23
5.4 Electrical System .....	23
6. Trouble Shooting Steps .....	24
6.1 Scenario:.....	25
7. Exploded View.....	27
8. Environment.....	28

# Safety Information

To prevent injury to anyone using this product and property damage, the following precautions must be followed:

- Read this manual before installing the product.
- Follow the Cautions in this document as they mention important points related to safety.
- Incorrect operation results in accidents that are denoted by special notations as below:

 **WARNING** This symbol indicates the possibility of death or serious injury.

 **CAUTION** This symbol indicates the possibility of injury or damage to properties only.

## **WARNING**

Follow the below warnings properly; else it might result in a fire disaster, explosion or a risk of incurring electric shock injuries.

Do NOT use a defective or underrated circuit breaker. Use this appliance on a dedicated circuit.

Do NOT carry out electrical work by yourself. Consult the dealer, seller, a qualified electrician, or an Authorised Service Center.

Always ground the connection.

Follow proper wiring and installation regulations for electrical equipment.

Be cautious when unpacking and installing the product to avoid injury from sharp edges.

Do NOT disassemble, install or repair the product by yourself. Consult the dealer, seller, a qualified electrician, or an Authorised Service Center.

Do NOT fill water in the DHW tank full to the brim as overflow might result in a slippery floor.

Do NOT install the product in a location that is subjected to deterioration. As, it may cause the product to trip; consequently damaging property and product malfunctioning.

# 1. General Information

This chapter provides general information regarding the DHW tank.

- a) Single/Double Coil water DHW tank manufactured according security requirements and Directive 2014/68/UE 15th May 2014, according laws concerning pressure equipment.
- b) This product complies with the Directives ErP 2009/125 CE and ELD 2010/30/UE.
- c) This document describes procedures that are compliant with the section 3.4 of annex I RD 97/23/EC.
- d) This manual is supplied with each unit.

## 2. Technical Features

This chapter describes the following sections in detail: Technical Details, Technical Drawings and Connections.

**Capacity range for Single Coil Water DHW tank (200-300 and 500 litres)**

**Capacity of cylinder Double Coil water DHW tank is (200-300 and 500 litres)**

**Stainless Steel material is used for mechanical construction (DHW tank, Single HEx and Connections). It is suitable for chlorinated water at a temperature of 60°C.**

- *Test pressure Prim. / Sec.: 12 / 12 bar.*
- *Max operating pressure Prim. / Sec: 6 / 6 bar.*
- *Designed temperature Min. / Máx.: 5 / 90 °C.*
- *Max operating temperature: 90 °C.*
- *Electrical kit: 230 V 50/60 Hz (Single-phase)*



Single/Double Coil water DHW tank, vertical installation for DHW production is feasible for commercial and residential purposes.

The cold water is heated inside the DHW tank using tubular coil that circulates water within the primary circuit, resulting in thermal exchange.

**NAME PLATE Displays:** Serial Number, Volume, Pressure, Manufacturing Year etc.

Ensure that the Name Plate is properly affixed on the DHW tank. Tampering with the Name Plate could result in warranty exemption.

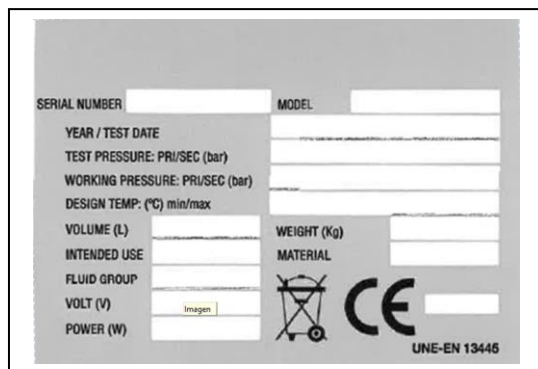

## 2.1 Technical Details

### (a) Single Coil

			LG 200F	LG 300F	LG 500F
General Characteristics	Water Volume	L	200	300	500
	Diameter	mm	640	640	810
	Height	mm	1350	1850	1900
	Empty Weight	kg	61	100	146
	Tank Materials		S.STEEL: F18	S.STEEL: F18	S.STEEL: F18
	Colour		GREY 7035	GREY 7035	GREY 7035
Characteristics of Electrical Back-up	Additional Electric Heater	kW	2,4	2,4	2,4
	Adjustable Thermostat	°C	90°C	90°C	90°C
Characteristics of Exchanger	Exchanger Type		INTERNAL SINGLE COIL	INTERNAL SINGLE COIL	INTERNAL SINGLE COIL
	Material Exchanger		S.STEEL: F18	S.STEEL: F18	S.STEEL: F18
	Maximum Water Temperature	°C	90	90	90
	Coil Surface	m <sup>2</sup>	2.3	3.1	4.8
Hydraulic Connections – Heat Pump	THERMA V Inlet	inch	1"	1"	1 ¼"
	THERMA V Outlet	inch	1"	1"	1 ¼"
Hydraulic Connections – Domestic Hot Water Tank	City Water Inlet	inch	3/4"	3/4"	1"
	Hot Water Outlet	inch	3/4"	1"	1"
Electric Connection	Supply	Ø / V / Hz	1/230/50(60)	1/230/50(60)	1/230/50(60)
Energy Efficiency Class			B	B	B
Standing Heat Loss		W	61	70	83
Storage Volume		L	200	300	500
Number of Coils		L	1	1	1

Heat loss: DHW tank preloaded at 65°C

**(b) Double Coil**

		Criteria	LG F18 Double Coil
General Characteristics	Water Volume	L	300
	Diameter	mm	640
	Height	mm	1850
	Empty Weight	kg	106
	Tank Materials		F18
	Colour		GREY 7035
Characteristics of Electrical Back-up	Additional Electric Heater	Kw	2,4
	Power supply Electric Heater	∅ / V / Hz	1/230/50(60)
	Adjustable Thermostat	°C	0-90
Characteristics of Exchanger	Exchanger Type		INTERNAL
	Material Exchanger		F18
	Maximum Water Temperature	°C	90
	Coil Surface	mm	3,1+0,97
Hydraulic Connections – Heat Pump	ThermaV Inlet	inch	1" (Sup 3/4")
	ThermaV Outlet	inch	1" (Sup 3/4")
Hydraulic Connections – Domestic Hot Water Tank	Domestic Hot Water Inlet	inch	3/4"
	Domestic Hot Water Outlet	inch	1"
Energy Efficiency Class			B
Standing Heat Loss		W	70
Number of Coils		L	2

## 2.2 Technical Drawings

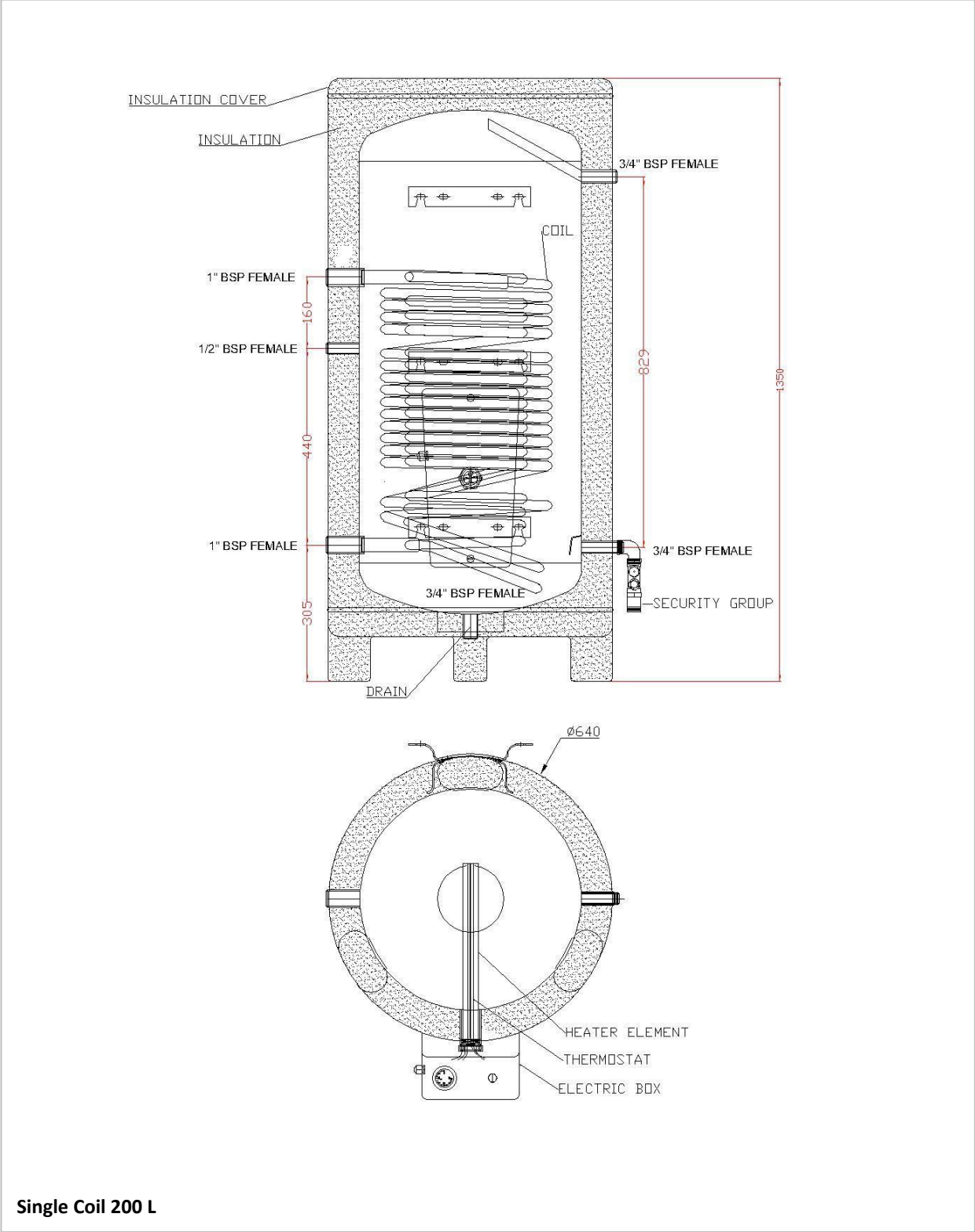



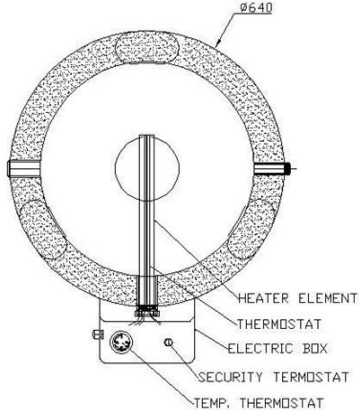
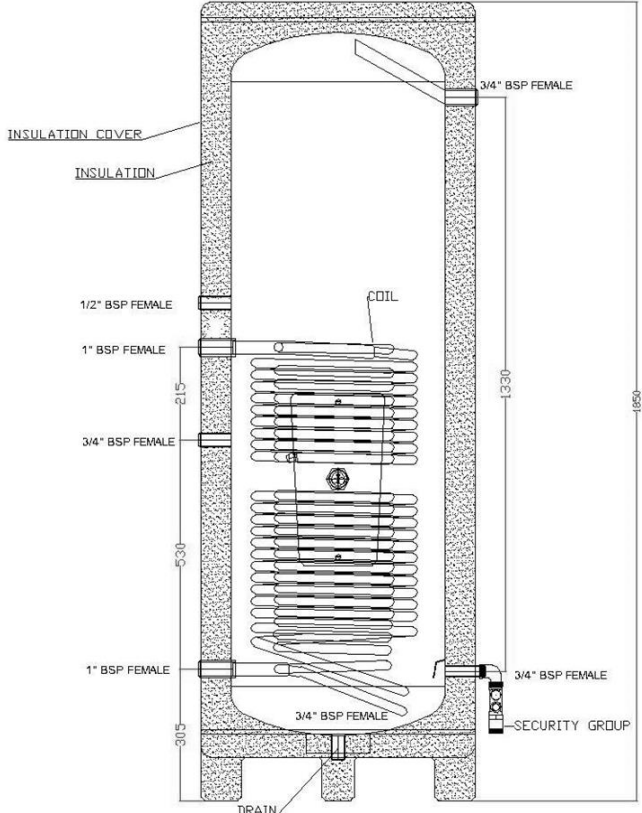

Single Coil 300 L

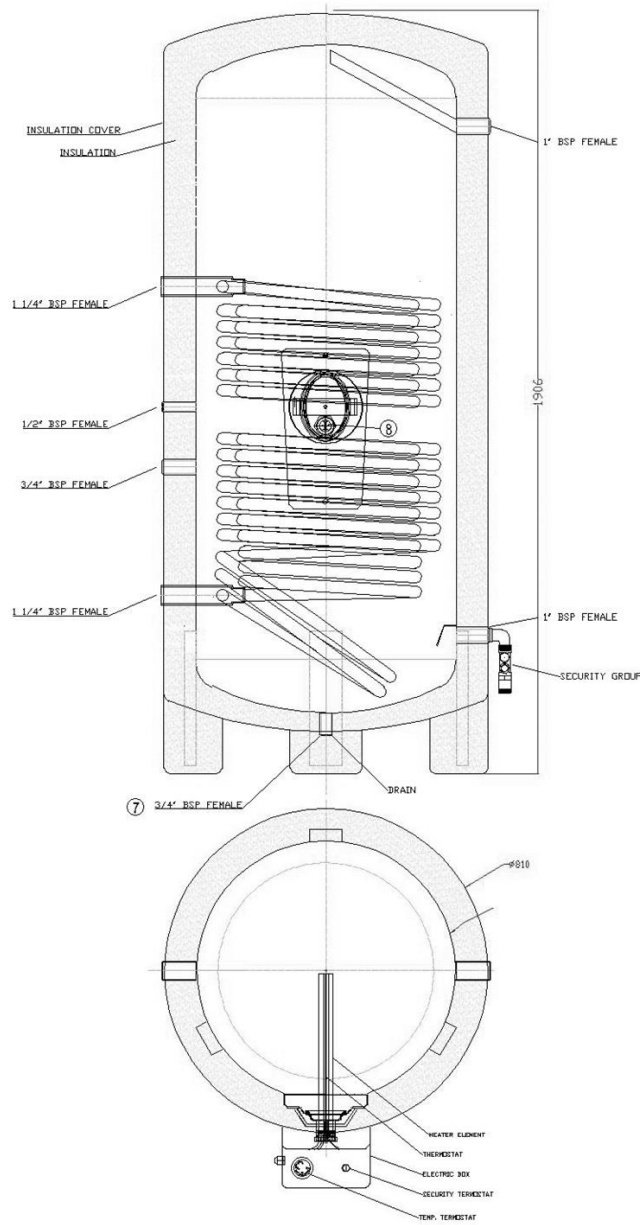

Single Coil 500 L

Single Coil	VOLUME		
	200	300	500
DIAMETER Ø mm	640	640	810
HEIGHT mm	1350	1850	1900

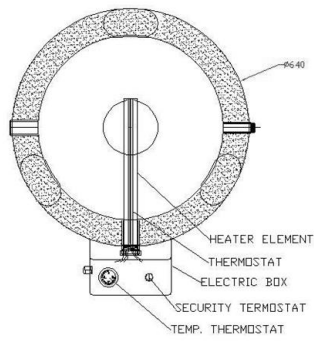
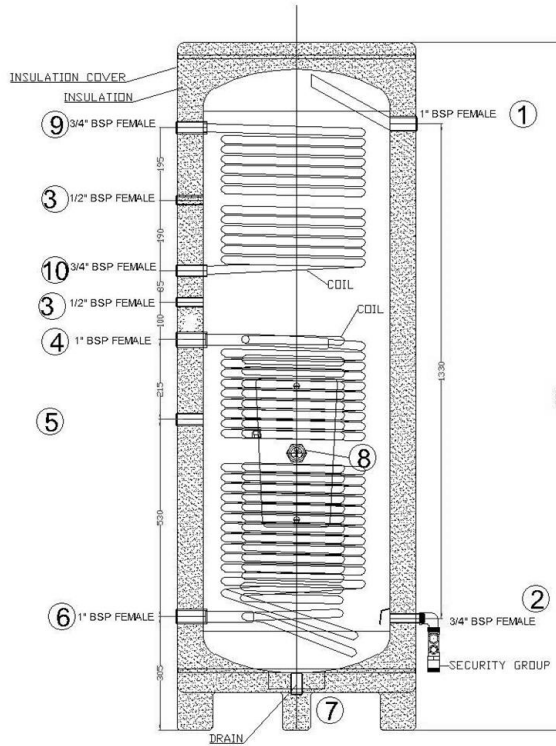

**Double Coil 300 L**

Double Coil	<b>300</b>
<b>DIAMETER Ø mm</b>	640
<b>HEIGHT mm</b>	1850

## 2.3 Connections

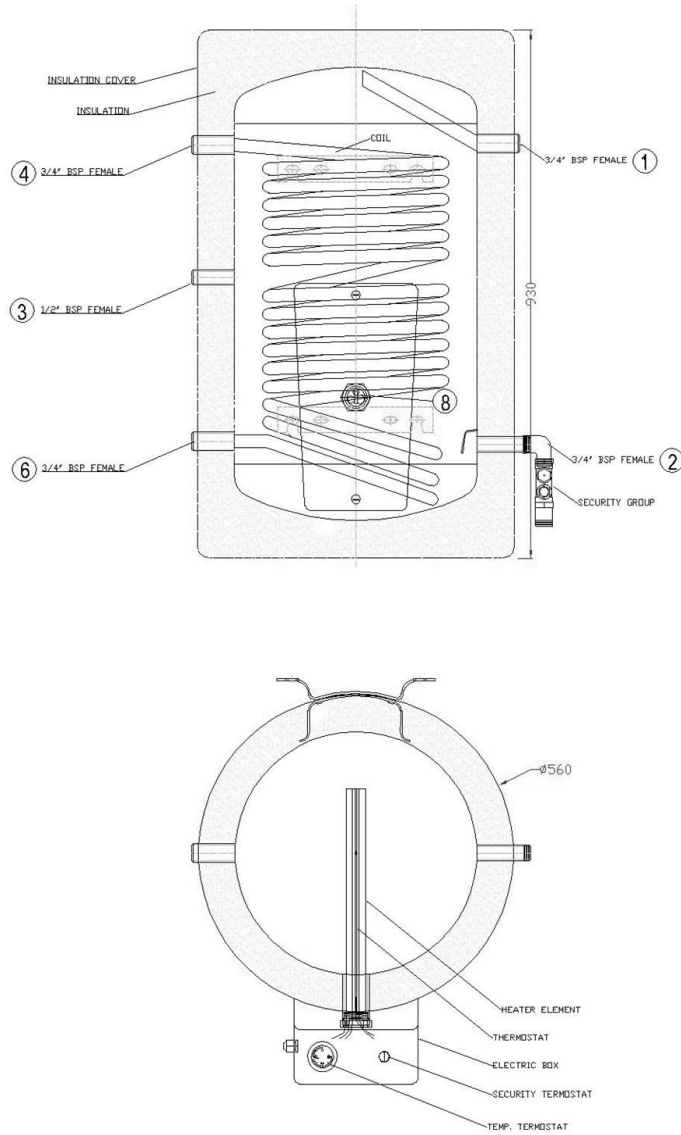

Single Coil

### Connections

- |   |                           |   |                  |
|---|---------------------------|---|------------------|
| ① | Hot water outlet          | ② | Cold water inlet |
| ③ | Thermostat                | ④ | THERMA V inlet   |
| ⑤ | Recirculation (300-500lt) | ⑥ | THERMA V outlet  |
| ⑦ | Drain (200-300-500 lt)    | ⑧ | Resistance       |

Single Coil 200 L

Connections

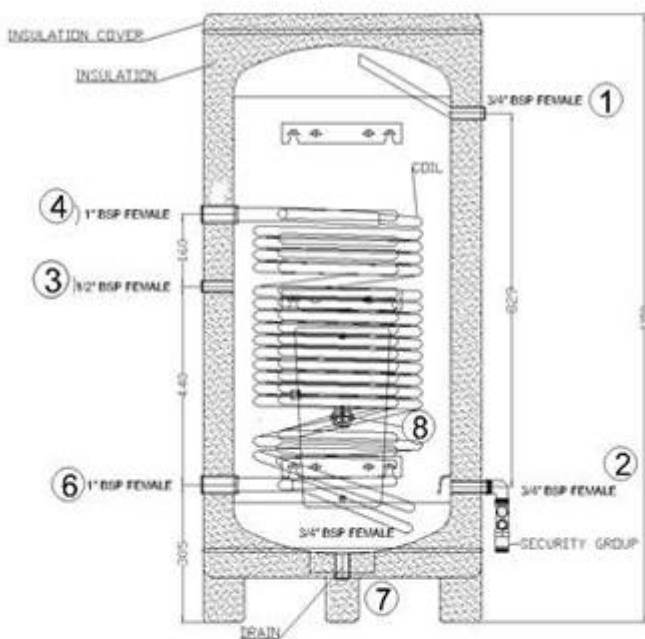

- ①
- ③
- ⑥
- ⑧

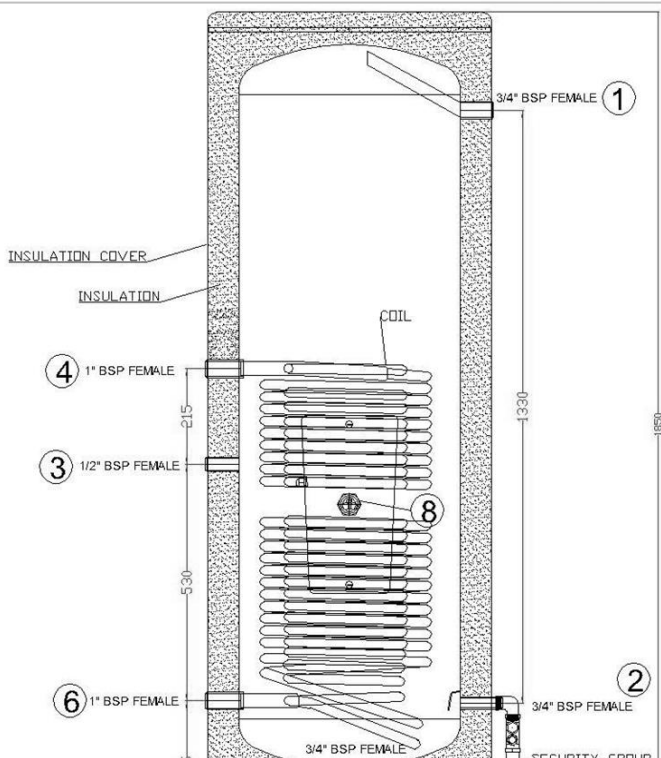
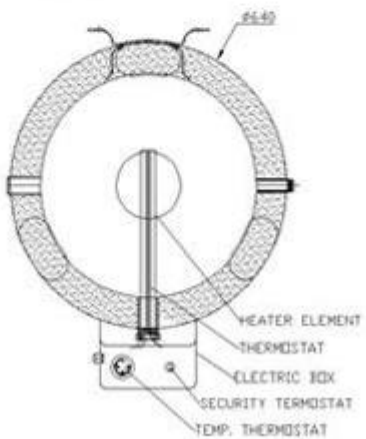

### Connections

- |   |                  |   |                  |
|---|------------------|---|------------------|
| ① | Hot water outlet | ② | Cold water inlet |
| ③ | Thermostat       | ④ | THERMA V inlet   |
| ⑥ | THERMA V outlet  | ⑦ | Drain (300lt)    |
| ⑧ | Resistance       |   |                  |

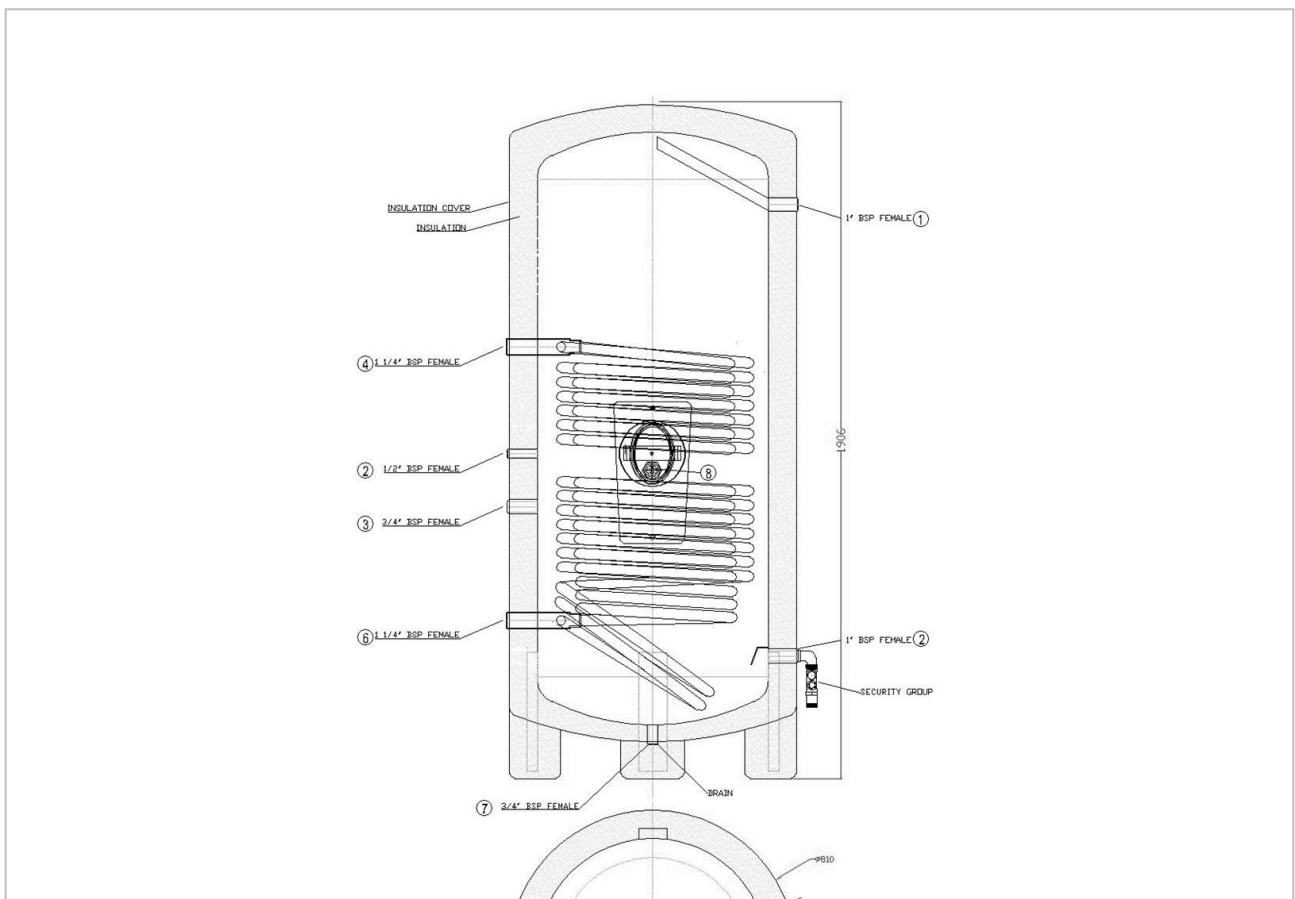

### Connections

- |   |                            |   |                  |
|---|----------------------------|---|------------------|
| ① | Hot water outlet           | ② | Cold water inlet |
| ③ | Thermostat                 | ④ | THERMA V inlet   |
| ⑤ | Recirculation (300 -500lt) | ⑥ | THERMA V outlet  |
| ⑦ | Drain (200-300-500 lt)     | ⑧ | Resistance       |

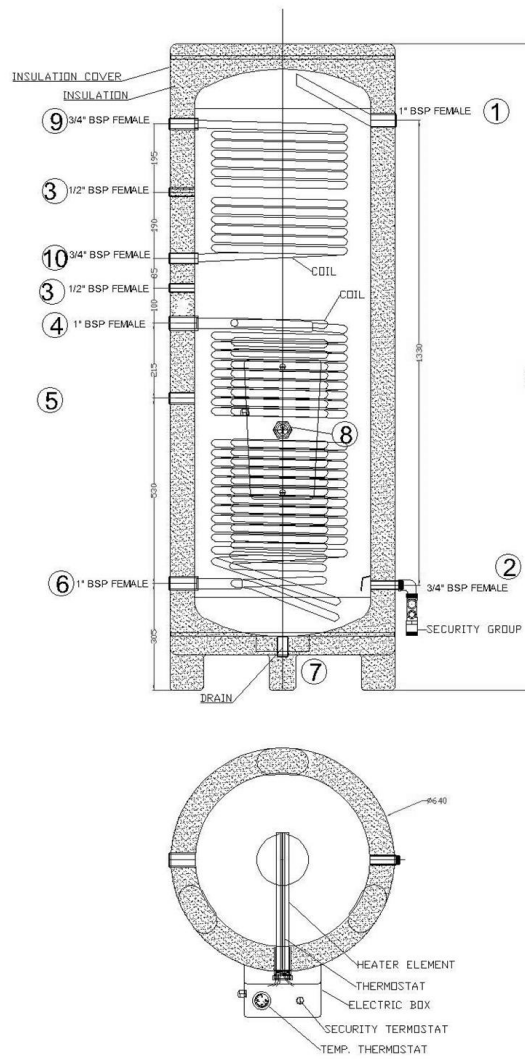

**Double Coil 300 L**

**Connections**

- |   |                          |   |                           |
|---|--------------------------|---|---------------------------|
| ① | <b>Hot water outlet</b>  | ② | <b>Cold water inlet</b>   |
| ③ | <b>Thermostat</b>        | ④ | <b>THERMA V inlet</b>     |
| ⑤ | <b>Recirculation</b>     | ⑥ | <b>THERMA V outlet</b>    |
| ⑦ | <b>Drain</b>             | ⑧ | <b>Resistance</b>         |
| ⑨ | <b>Heat source inlet</b> | ⑩ | <b>Heat source outlet</b> |

	1	2	3	4	5	6	7	8	9	10
200	3/4	3/4	1/2	1"	-	1"	3/4	11/4	-	-
300	1"	3/4	1/2	1"	3/4	1"	3/4	11/4	-	-
500	1"	1"	3/4	11/4	1/2	11/4	3/4	11/4	-	-
300 Double	1"	3/4	1/2	1"	3/4	1"	3/4	11/4	3/4	3/4



## 3. Installation

This chapter describes the following sections in detail: Location, Hydraulic Connections, Three-Way Thermostatic Mixing Valves, Connection Recommendations, Installation Examples and Installation of the DHW Tank.

### 3.1 Location

The Single Coil DHW Tank installation should be installed indoors as per the recommended guidelines as follows:

- a) Floor Standing, Vertical Mounting: Do NOT fill water in the DHW tank full to the brim as overflow might result in a slippery floor.

Ensure that the location is easily accessible for repair and maintenance of the DHW tank.

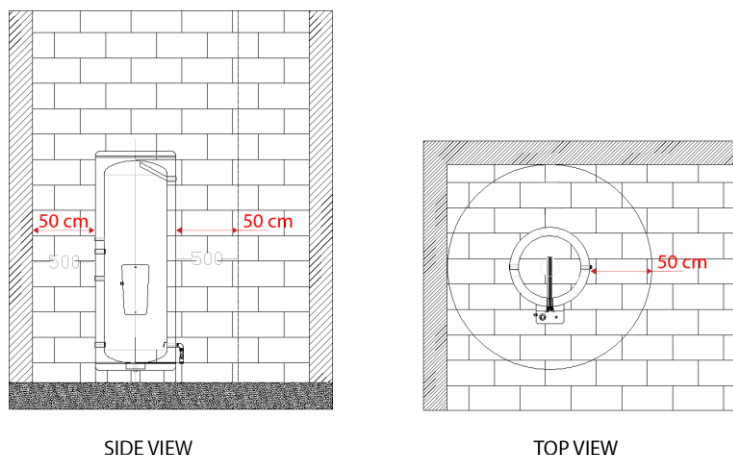

- b) For maximum performance, install the DHW tank in frost free places.

### 3.2 Hydraulic Connections

The DHW tank has a safety set, to carry out the following functions: Filling, Emptying, Non-Return Valve and Safety Valve (cut-OFF at 6 bars)

Once it has been installed, the mains water pipeline should be flushed. To comply with the recommended regulations, fit a siphon in the drain.

If the public water pressure exceeds 5 bars, use a pressure reducer (Safety Compliant).

Whilst the tank is in use the stopcock must be open. The check valve may be mounted and controlled without hindering other users.

The Safety Valve allows hot water to be drained when:

- The pressure reaches 6 bars.
- When there is a heating malfunction; thus limiting the maximum pressure at 8 bar.

### 3.3 Three- Way Thermostatic Mixing Valves

The Compact Thermostatic Mixing Valve is designed to supply general purpose applications such that the temperature of water does not exceed the standard temperature that is set by the valve.

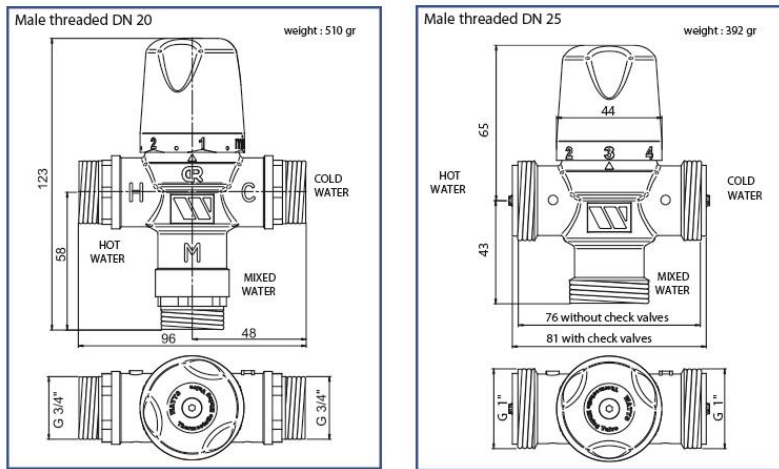

Ideal for environments: Domestic homes, schools, restaurants, laboratories, motorway services, commercial buildings etc. that require a supply of water at a temperature preset on site.

Note:

- Compliant with standards EN1111 and EN1287.
- Brass DZR body and WRAS approved.
- MMV-C with compression fitting 22 mm and 15 mm are TMV2 approved.

Typical installation :

Point of use control

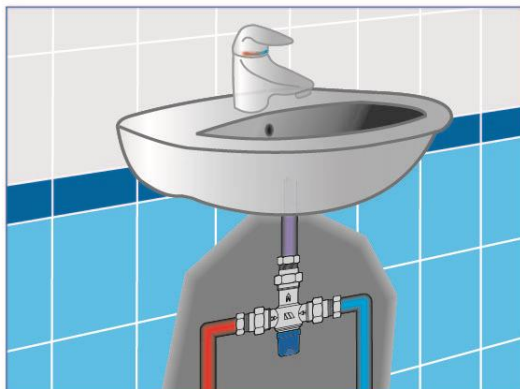

Boiler control

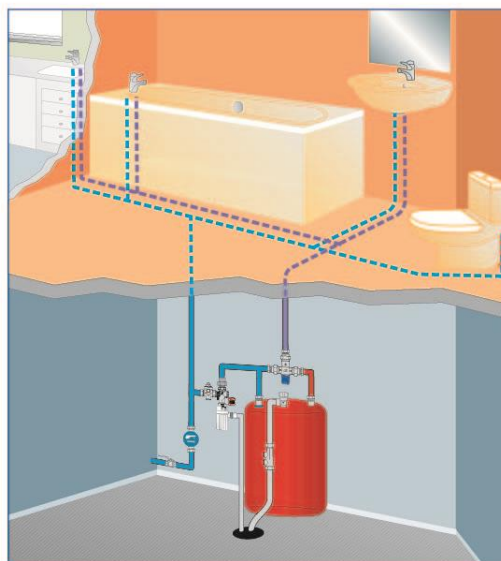

### 3.4 Connection Recommendations

- Primary circuit (coil) must be connected to the heat source inlet and outlet.
- Temperature probe (heat pump regulation).
- Drain on bottom of DHW tank.
- An expansion vessel should be installed in primary circuit (return).

### 3.5 Installation Examples

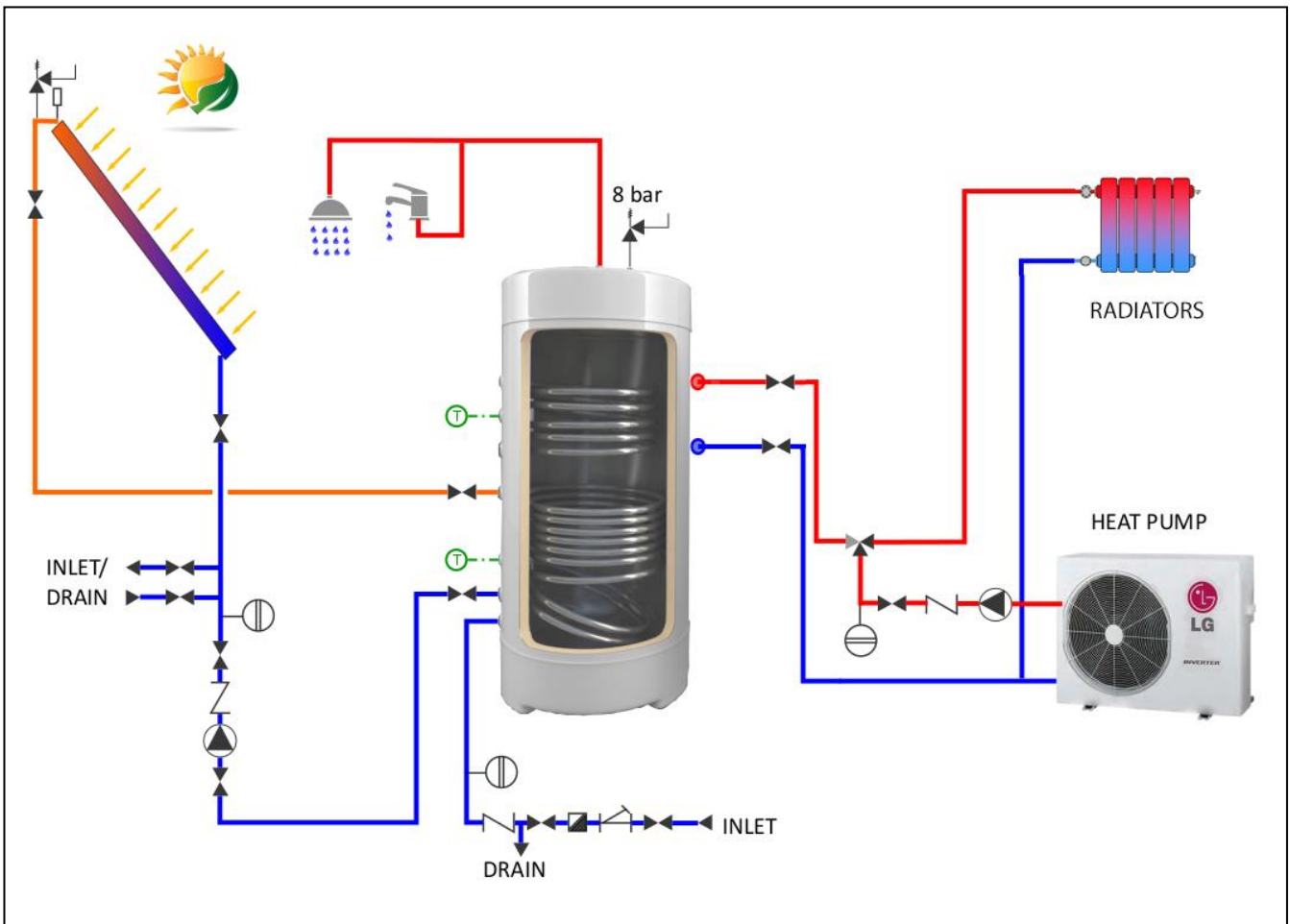

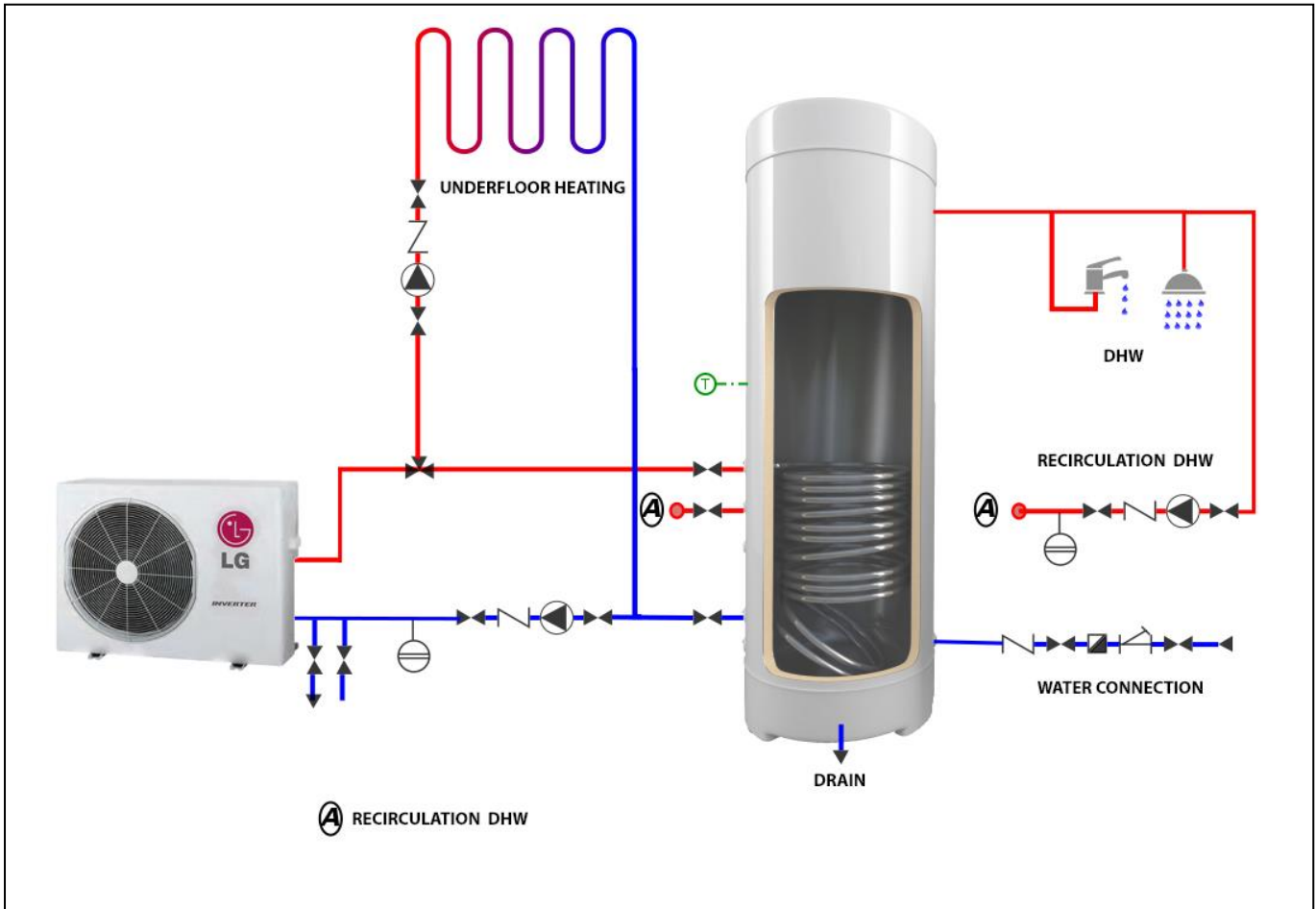

### 3.6 Installing the DHW Tank

Once installed, the DHW tank needs to be filled up with water slightly below the brim. Open the stopcock, a hot water tap (shower, sink etc.) and cold water tap to let air purge from the DHW tank and then close the hot water tap.

Fill up the heat transfer fluid and set the temperature thermostat to 90 °C. The heat pump will automatically switch ON until water in the DHW tank reaches the desired temperature.

If the heat pump controls the tank resistance set a top temperature (to prevent stop the flow) otherwise set the temperature supply to 80 °C

While heating the DHW tank, if there is a leak in the Safety Valve, DO NOT IGNORE. As, this might result in bursting/explosion of the DHW tank. In such a scenario, DRAIN THE EXCESS WATER TO A SAFE/UNAFFECTED AREA.

Verify that the connections do NOT leak, tighten if necessary. If the problem persists after 24-48 hours, contact your Distributor.

## 4. Maintenance

This chapter describes the Service, Maintenance and Diagnostics to be performed by a qualified technician or Company, following the relevant regulations and the instructions in this manual.

Chemical disinfection with chlorine is recommended, please read carefully and proceed as follows:

- Chlorinate the DHW tank water using 20-30 mg/l chlorine, at a temperature lower than 30 °C and a pH of 7-8, such that all connection points are valuated at at 1-2 mg/L.
- Expose the DHW water tank to chlorine for 2-3 hours. As an alternative option, you can use 4-5 mg/L inside the DHW tank for 12 hours.
- Refill with water and restore normal conditions of use.
- To neutralise the residual chlorine in the DHW tank. Fill and drain with water several times.

**In the case of thermal disinfection, proceed as follows:**

- Drain the DHW tank and rinse with clean water.
- Fill up the DHW tank with water and raise the temperature up to 70°C maintaining this temperature for at least 2 hours.
- Open all hot water taps and showers, for 5 minutes, sequentially. Check that the water temperature from the taps and shower are at 60°C.
- When this process is finished, follow the instructions described in this manual.
- For external cleaning, it is recommended to use a moist cloth and mild cleaning agents. Do NOT use strong cleaning agents.

It is advisable to drain the DHW tank if it remains unused for a long period of time to prevent risk of frost setting in.

### Water characteristics

The supplier represents and warrants that Products shall:

- a) be free from defects, including any latent defects, in design, materials and workmanship applicable thereto for a period of 10 years for products manufactured in stainless steel. Duplex 2205 and 5 years for products manufactured in Stainless Steel F18 only when water supply conditions are maximum value 250 p.p.m CO<sub>3</sub>Ca at 80 ° C. (The warranty period)
- b) conform to specifications, if applicable.
- c) Be new, unused and not contain used or repaired parts.
- d) be free and clear of all liens, claims, encumbrances, and other restrictions.
- e) does not contain any dangerous or hazardous substances or materials.

## 5. Security

This chapter describes the following sections in detail: Electrical Kit, Electrical Schematics, Elements and System.

Ensure that the maximum system pressure has not exceeded the value as indicated in this document. Similarly, ensure that the values obtained while operating the DHW tank do NOT exceed that of the Name Plate's technical characteristics.

Do NOT disconnect the DHW tank, without reducing the internal pressure of the DHW tank first.

Do NOT use the DHW tank for any different purpose other than that intended.

### 5.1 Electrical Kit

This Single/Double Coil DHW tank is supplied with immersion heater as a backup, or whenever the user has to increase the temperature. It includes:

- Immersion Heater
- Temperature Thermostat
- Safety Thermostat

### 5.2 Electrical Schematic

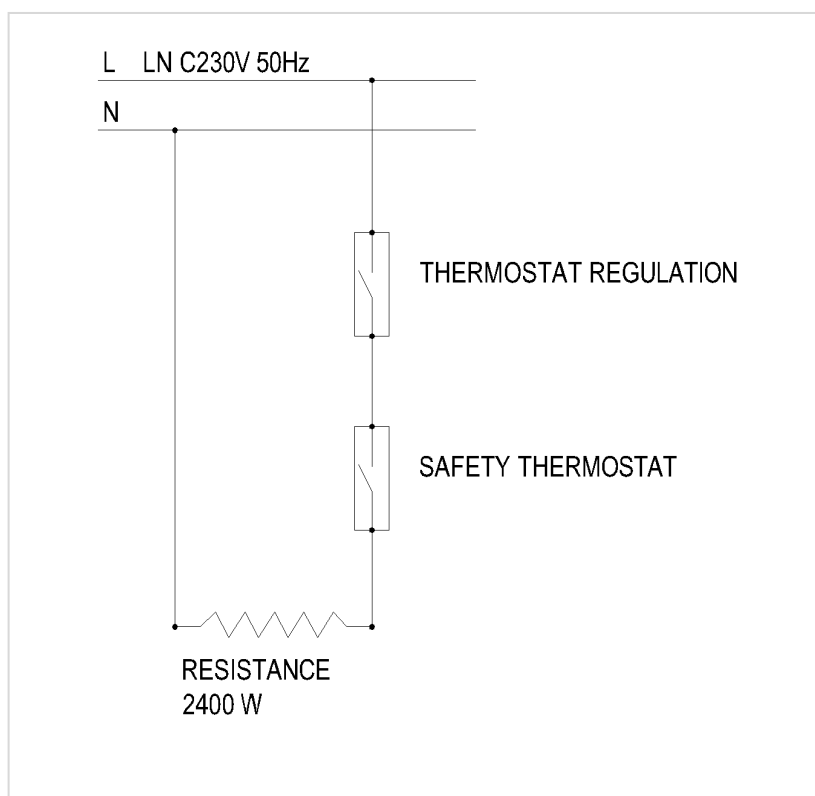

## 5.3 Electrical Elements

### (a) Control Panel

The Control Panel is responsible for operation of the immersion heater. It includes a thermostat, a safety thermostat and the heating element.

### (b) Immersion Heater Element

The heating element operates to warm up the water. The element is sheathed in Stainless Steel for easy replacement. While replacing, it is not mandatory to drain the DHW tank. The Operating Voltage is at 230 V @ 50/60 Hz.

#### Sheath for Temperature Sensor

For temperature and security thermostats:

- Length: 200 mm
- Diameter: 8 Ø

## 5.4 Electrical System



Do NOT operate the Immersion Heater if the DHW tank is not filled with water, as this could damage the electrical components. The electrical system must be controlled by using the Control Panel.

### (i) Temperature Thermostat

Set the temperature initially to be reached by the heating element to 60°C.

### (ii) Safety Thermostat

It prevents water heating in case of component malfunction (i.e. temperature thermostat). Safety thermostat cut-OFF is set at 110°C.

To verify if the safety thermostat is ON, first remove the plastic cover. If the red button sticks out from the thermostat, it means that the Safety Thermostat has cut-OFF.

In such a scenario, switch OFF the electric system and consult your service provider. Do NOT use the hot water as to avoid burns.

When turning ON the immersion heater, set the temperature to the desired temperature (60°C)

Do NOT operate the product with wet hands on a wet floor; as this might result in electric shock.

## 6. Trouble Shooting Steps

This chapter describes the various troubleshooting steps to be followed for issues rising from different scenarios.

FAULT	POSSIBLE CAUSE	REMEDY
No water flow from hot taps	Mains supply is OFF.	Check and open stopcock.
	Strainer blocked.	Turn OFF water supply. Remove strainer and clean.
	Cold water inlet Pressure Reducing Valve incorrectly fitted.	Check and refit as required,.
Water from hot taps is cold.	Immersion heaters not switched on.	Check and switch on.
	Immersion heater thermal cut-out has operated.	Check and reset button
	Programmer set to central heating or not switched on.	Check and set to hot water.
	Boiler not working.	Check boiler operation. If fault suspected consult installer or boiler manufacturer.
	Cylinder thermal cut-out has operated.	Check and reset button
	Control temperature is not properly set	Adjust to desired temperature
Intermittent water discharge.	Thermal control failure. (Note Water may be hot).	Switch OFF power to immersion heater(s) and boiler supply to the unit. When discharge has stopped, check thermal controls, replace if faulty. Contact a competent person.
Continuous water discharge	Cold water inlet Pressure Reducing Valve not working.	Check pressure from valve
	Temperature and pressure relief valve faulty.	Check and replace if faulty
	Expansion relief valve not working correctly.	Check and replace if faulty
Dropping water	Failure in security group of valves	Check pressure and temperature and replace if faulty

**Note :** Disconnect electrical supply before removing any electrical equipment covers



## 6.1 Scenario:

(a) There is no water from the hot tap:

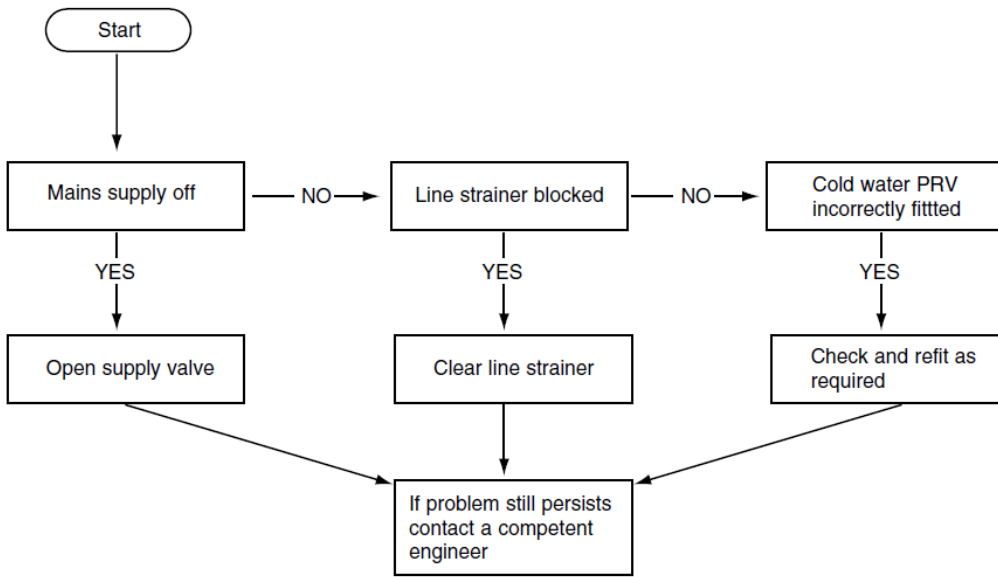

(b) The water from the hot tap is cold:

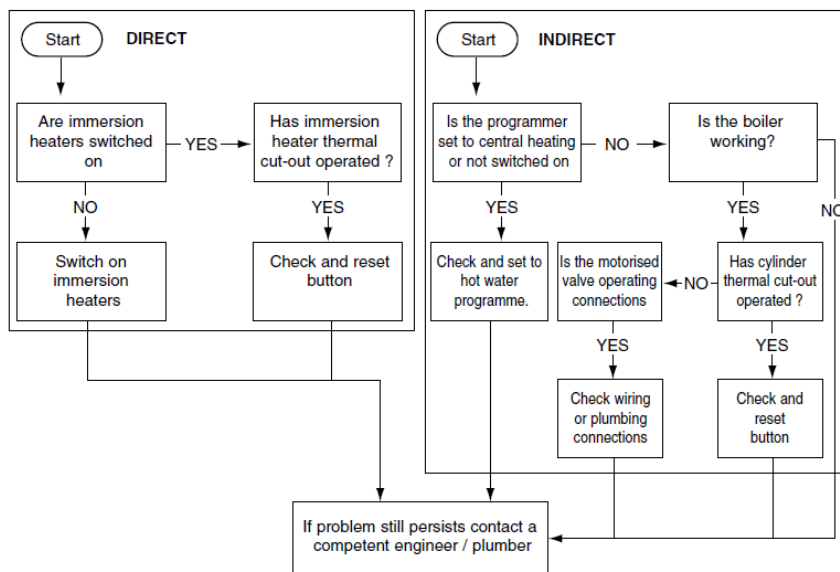

**(c) There is intermittent water discharge:**

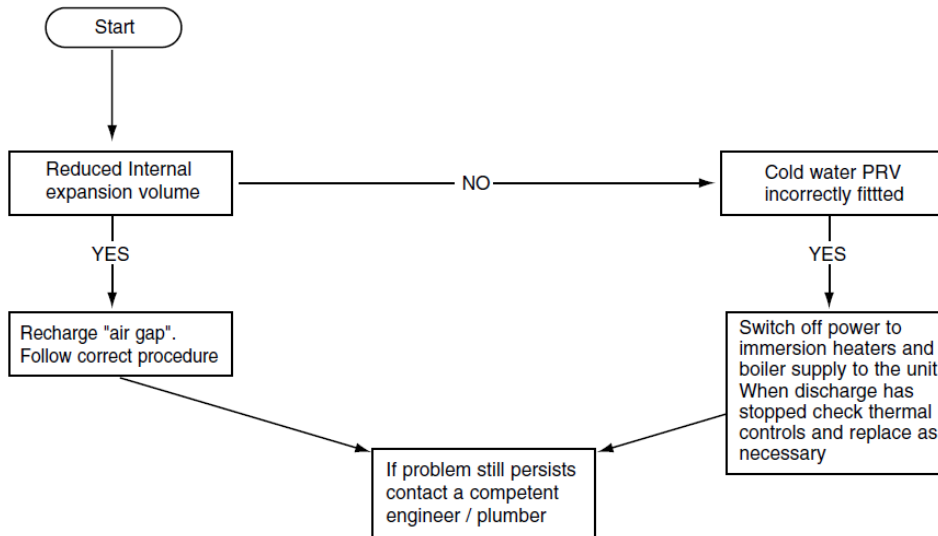

**(d) There is continuous water discharge:**

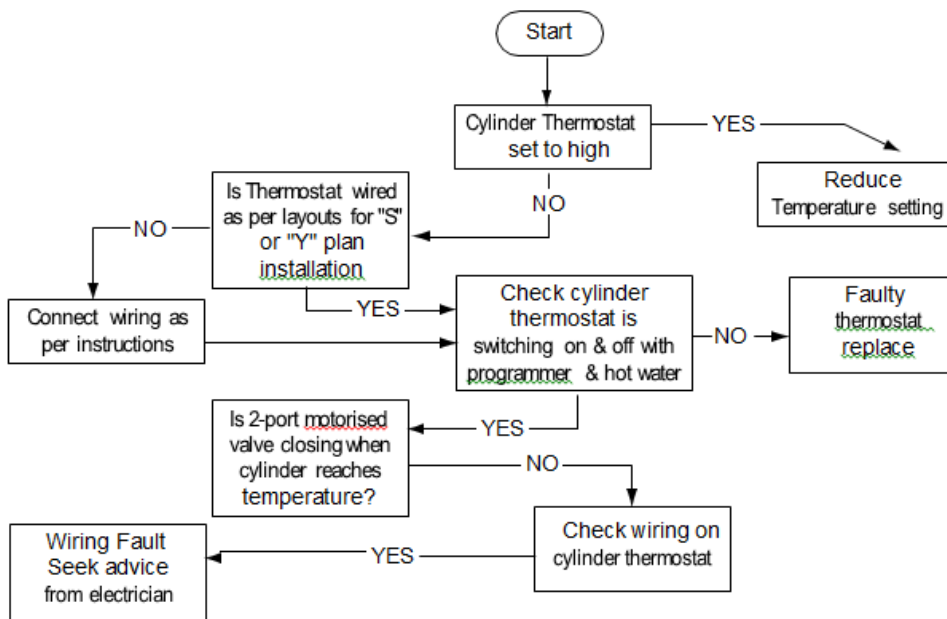

## 7. Exploded View

This chapter displays the graphical exploded view of the DHW tank.

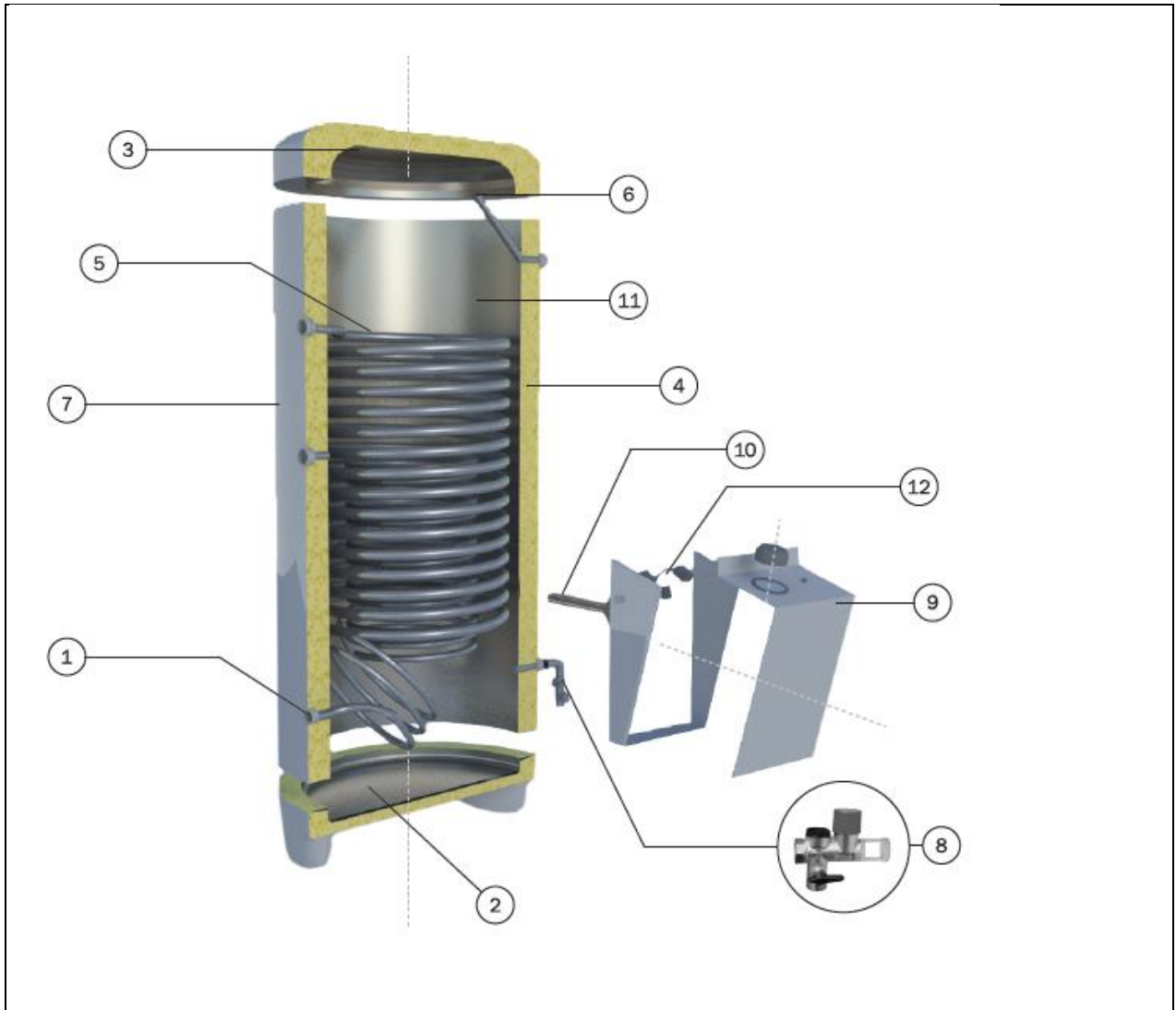

PARTS DHW TANK	
1	Connections
2	Bottom s.steel Section
3	Top s.steel Section
4	Insulation foam
5	Coil
6	DHW outlet
7	Polyester external casing
8	Safety group
9	Electrical panel
10	Imersion Heater 2.4KW
11	Stainless Steel tank
12	Electric panel connections

## 8. Environment

This chapter describes as to how environment friendly the DHW tank is and the directives it complies with.

As a manufacturer of electrical equipment and due to our commitment to protect the environment against hazardous chemicals, the cost derived from recycling of the equipment adheres to the principles of ECOTIC Foundation.

Once the life span of the DHW tank has expired, this product can be recycled by supplying it to:

- Council Recycling Point
- Distributor
- (CAC) by ECOTIC

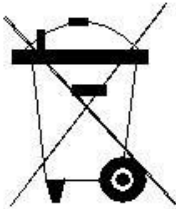

### WEEE symbol

*Waste Electrical and Electronic Equipment Directive (WEEE Directive) is the European Community Directive 2012/19/EU on waste electrical and electronic equipment (WEEE)*

*This symbol indicates that when the end-user wishes to discard this product, it must be shipped to separate collection facilities for recovery and recycling. By separating this product from other household-type waste, the volume of waste sent to incinerators or Landfills will be reduced and natural resources will thus be protected and conserved.*